



# INSTALLATION INSTRUCTIONS

Accessory  
TRAILER HITCH

Application  
2010 MDX

Publications No.  
BII 42104  
Issue Date  
JAN 2010

## PARTS LIST

### Trailer Hitch Kit P/N 08L92-STX-200

Trailer hitch

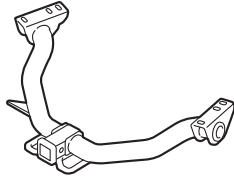

Left bracket

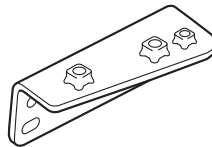

Right bracket

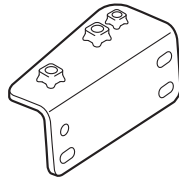

12 Washer bolts, 14 x 40 mm

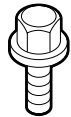

2 Washer bolts, 12 x 33 mm

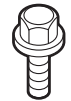

12 Washers, 14 mm



2 Washers, 12 mm



Ball mount

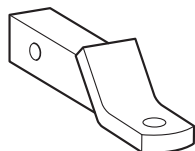

Receiver cover

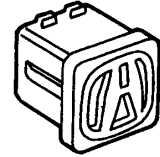

Hitch pin



Hitch pin clip



### Trailer Harness Kit P/N 08L91-STX-200A

Trailer hitch control unit

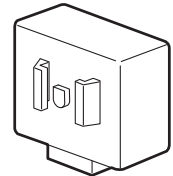

Trailer socket

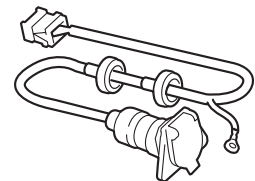

Control unit bracket

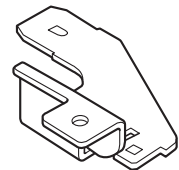

Socket bracket

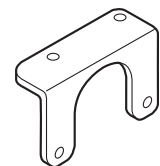

Control unit harness

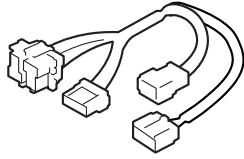

Subharness

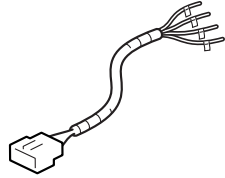

2 Relays

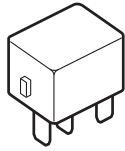

2 Fuses (7.5A)

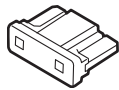

3 Fuses (20A)

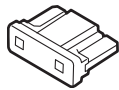

5 Wire ties

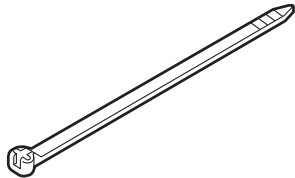

5 Flange bolts, 6 x 16 mm

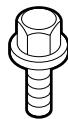

Accessory User's Information Manual

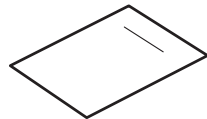

## TOOLS AND SUPPLIES REQUIRED

Phillips screwdriver

Diagonal cutters

Plastic trim tool (T/N SILTRIMTL10)

Clip remover

Ratchet

10 mm, 17 mm, and 19 mm Sockets

10 mm Wrench

Torque wrench

19 mm Combination wrench

Gloves

### *Illustration of the Trailer Hitch Installed on the Vehicle*

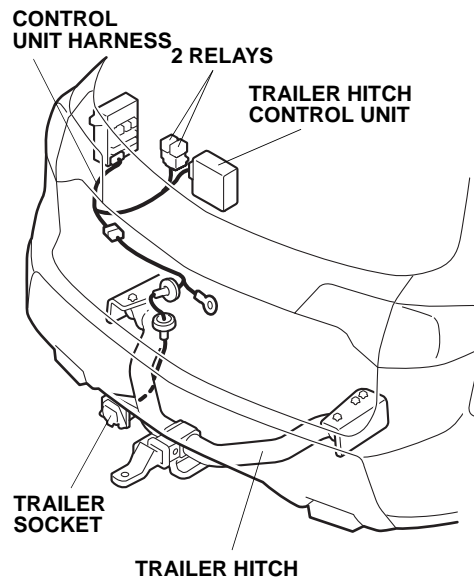

## INSTALLATION

**Client Information:** The information in this installation instruction is intended for use only by skilled technicians who have the proper tools, equipment, and training to correctly and safely add equipment to your vehicle. These procedures should not be attempted by “do-it-yourselfers.”

### NOTE:

- Be careful not to damage the rear bumper or other surfaces of the body.
  - Allow the exhaust system to cool down before installing the trailer hitch.
1. Make sure you have the anti-theft code for the radio, then write down the frequencies for the preset buttons.
  2. Disconnect the negative cable from the battery.
  3. Open the tailgate and locate the trim cover. Open the trim cover. Using the vehicle wheel wrench, lower the spare tire completely.

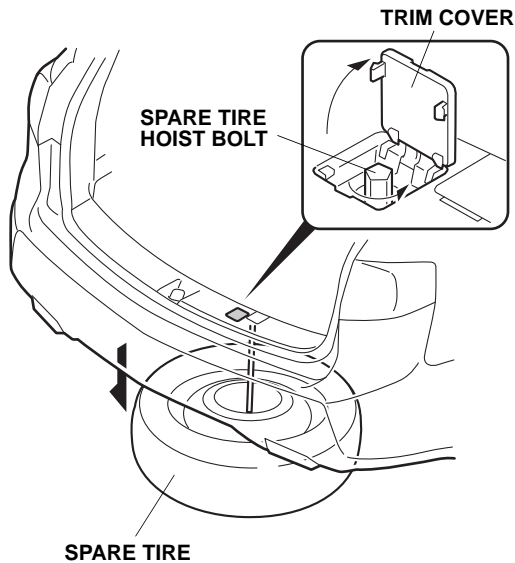

4. Remove the rear bumper trim from the rear bumper (10 clips). Set the rear bumper trim aside, it will not be reused.

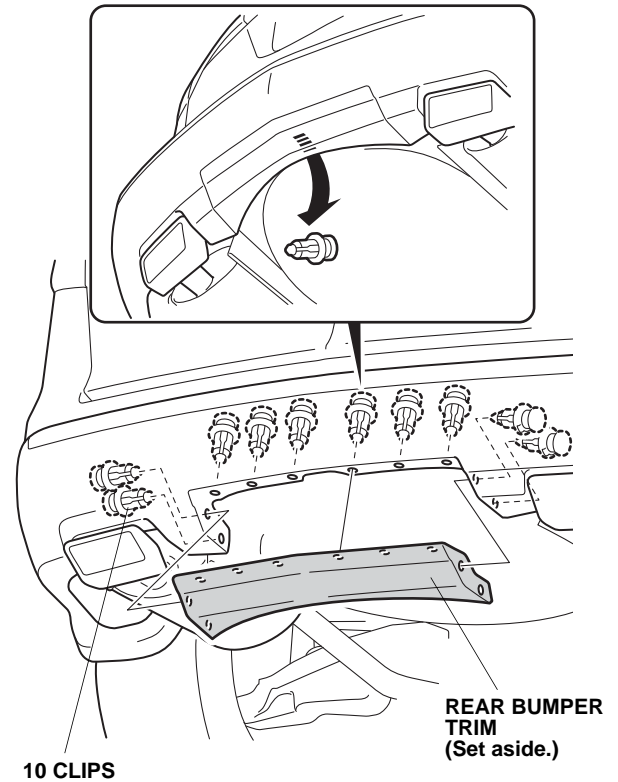

5. When the exhaust system has cooled down, remove the two rubber mounts that secure the left muffler to the body, then carefully lower the exhaust system. Lower the right muffler the same way.

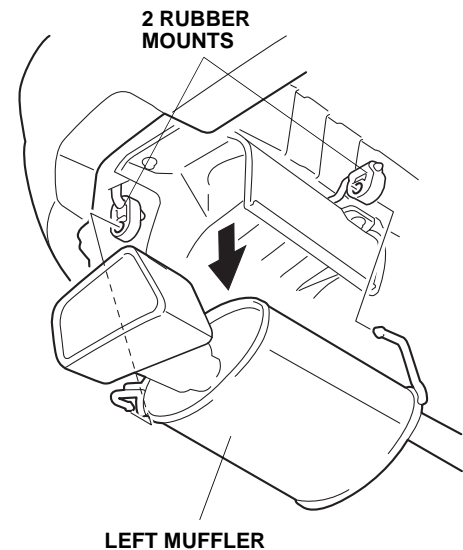

6. Remove the left heat shield (three washer bolts).

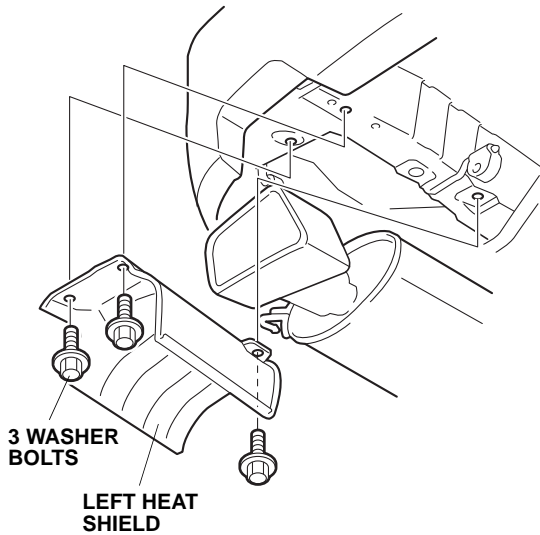

7. Remove the right heat shield (three washer bolts).  
 8. Position the left bracket on the body, and install four 14 x 40 mm washer bolts and four 14 mm washers. Torque the bolts to 75 N·m (55 lb-ft).

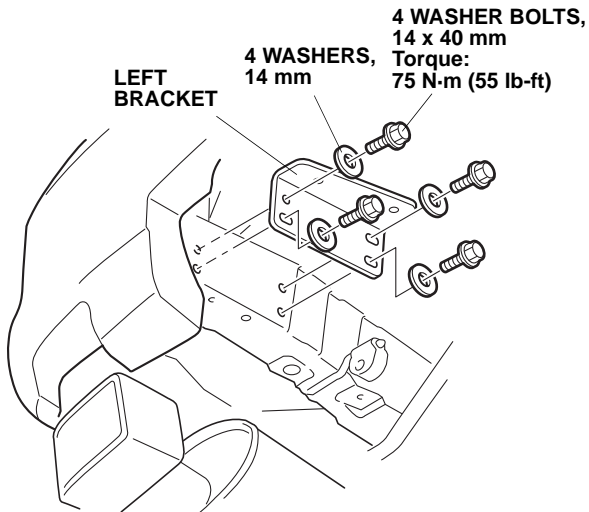

9. Install the right bracket the same way.

10. Install the socket bracket to the trailer hitch with two 6 x 16 mm flange bolts.

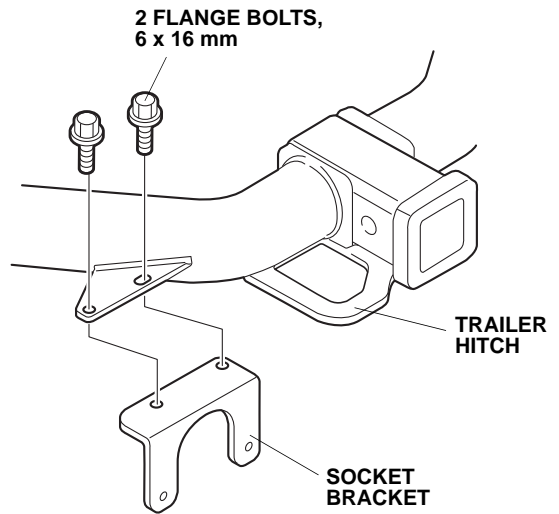

11. With the help of an assistant, position the trailer hitch under the body. Loosely install the two 12 x 33 mm washer bolts with two 12 mm washers, and the four 14 x 40 mm washer bolts with four 14 mm washers.

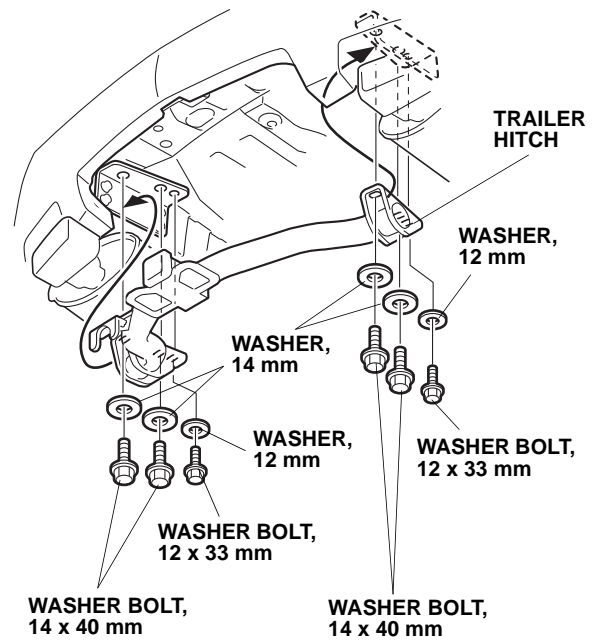

- Torque the 14 x 40 mm washer bolts to 95 N·m (70 lb-ft), then torque the 12 x 33 mm washer bolts to 58 N·m (43 lb-ft).

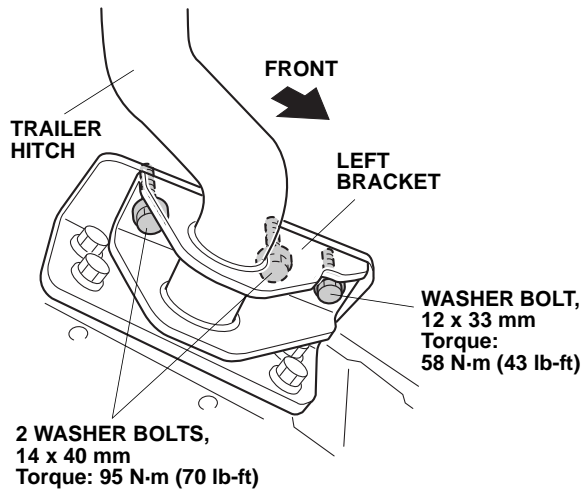

- Torque the right bolts the same way.
- Reinstall the heat shields and rubber mounts.

### Routing the Control Unit Harness

- Lift up the lock handle and remove the rear cargo floor lid.

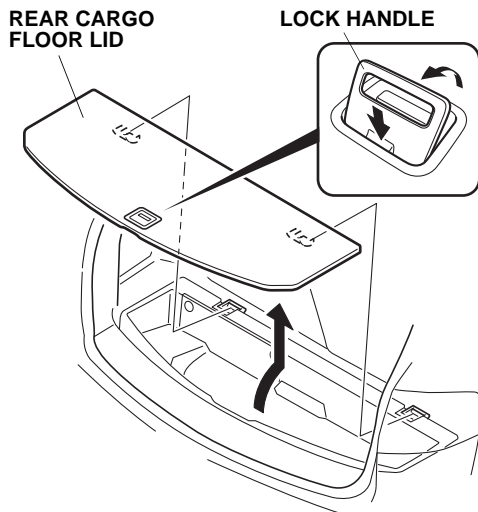

- Turn the knobs, then remove the cover from the rear cargo tray.

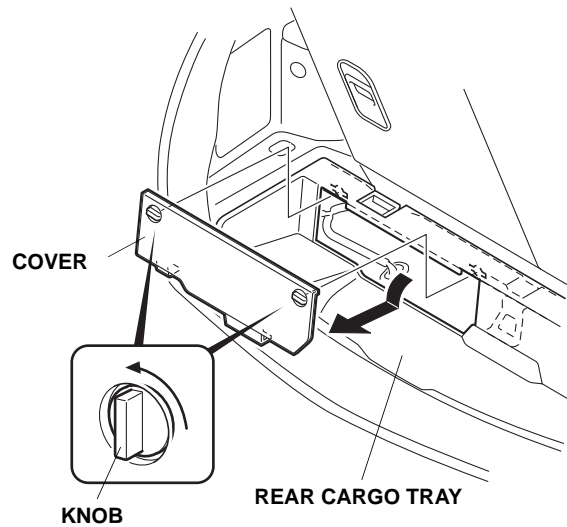

- Remove the rear trim panel (four retaining tabs and four clips).

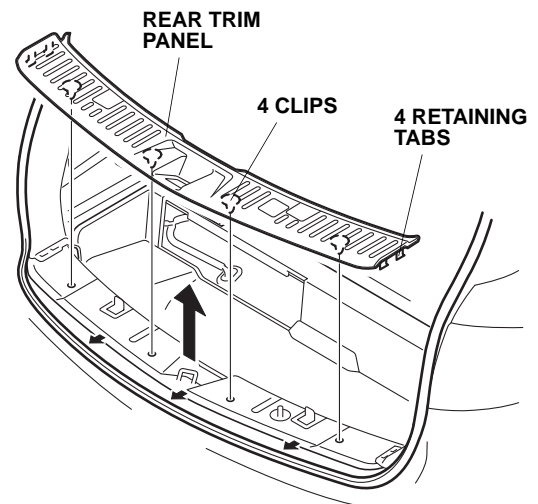

18. Remove the two cargo lid hinges (two self-tapping screws), and remove the rear cargo tray.

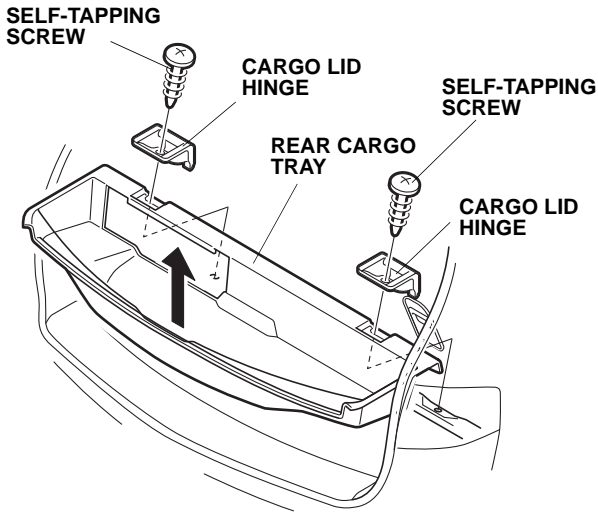

19. Remove the fuse box lid from the left rear side lining (five clips and two retaining tabs).

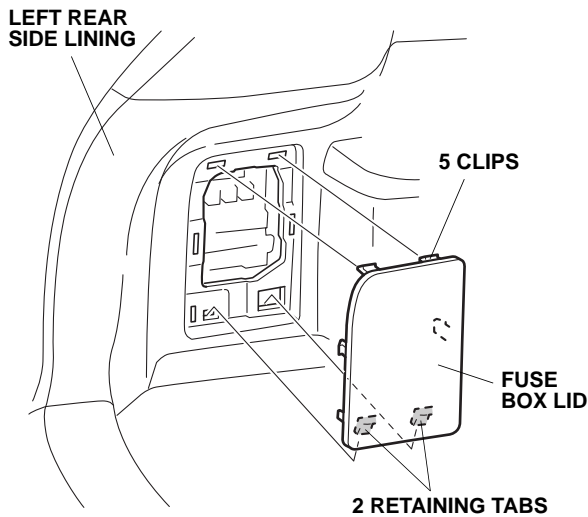

20. Remove the three mounting bolts from the vehicle control unit, then move the vehicle control unit out of the way without unplugging the connector.

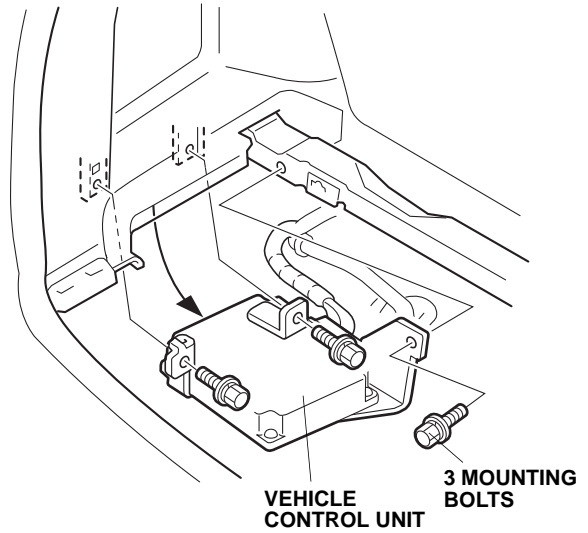

21. Slide the control unit bracket onto the trailer hitch control unit.

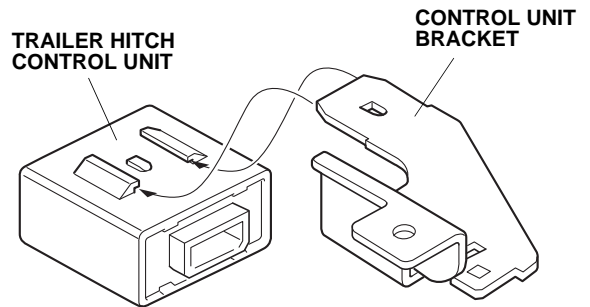

22. Install the two relays to the control unit harness relay block.

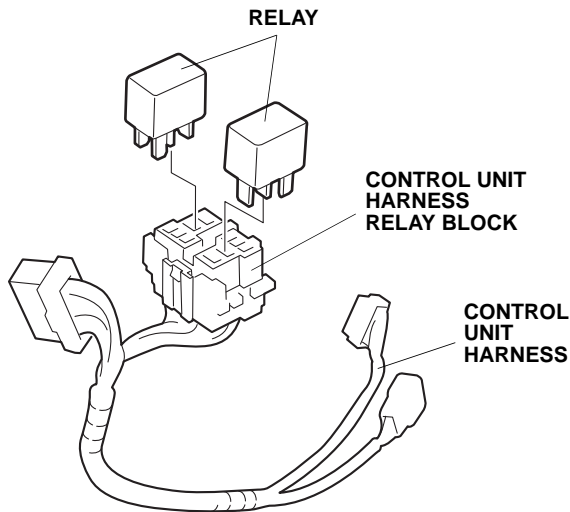

23. Plug the control unit harness 12-pin connector into the trailer hitch control unit.

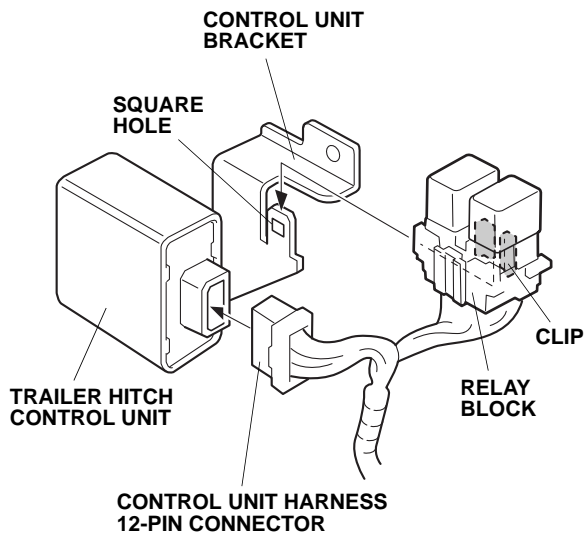

24. Push the clip on the relay block into the square hole in the control unit bracket.

25. Position the control unit bracket on the vehicle frame and install the 6 x 16 mm flange bolt.

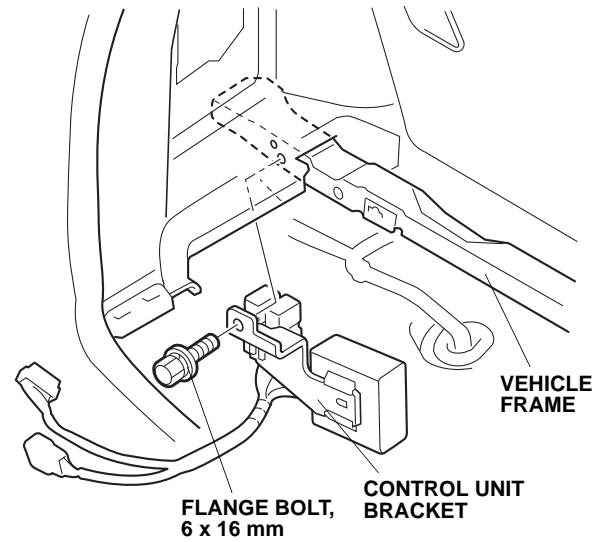

26. Route the control unit harness 14-pin connector under the left rear side lining, and plug the control unit harness 14-pin connector into the rear fuse box as shown.

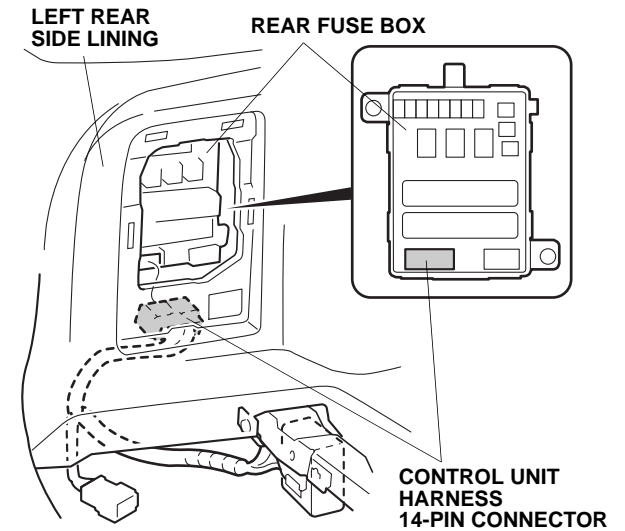

## Installing the Trailer Socket

27. Slide the 7-pin socket into the socket bracket, and secure the 7-pin socket with two 6 x 16 mm flange bolts.

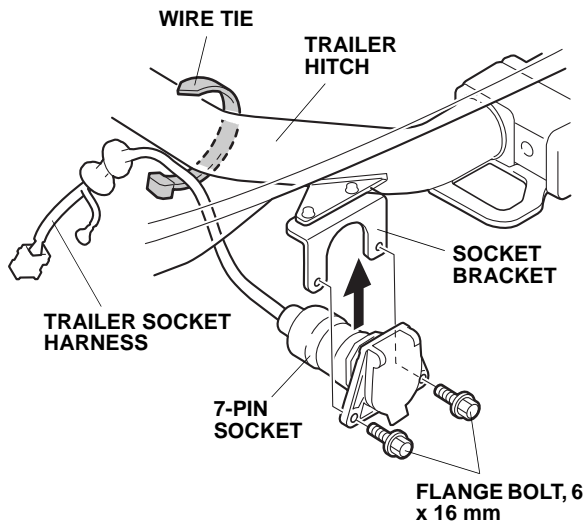

28. Attach the trailer socket harness to the trailer hitch with one wire tie.

29. Inside the cargo area along the rear panel, locate and remove the grommet from the body panel. Under the vehicle, locate and remove the grommet from the bottom body panel. Discard both grommets.

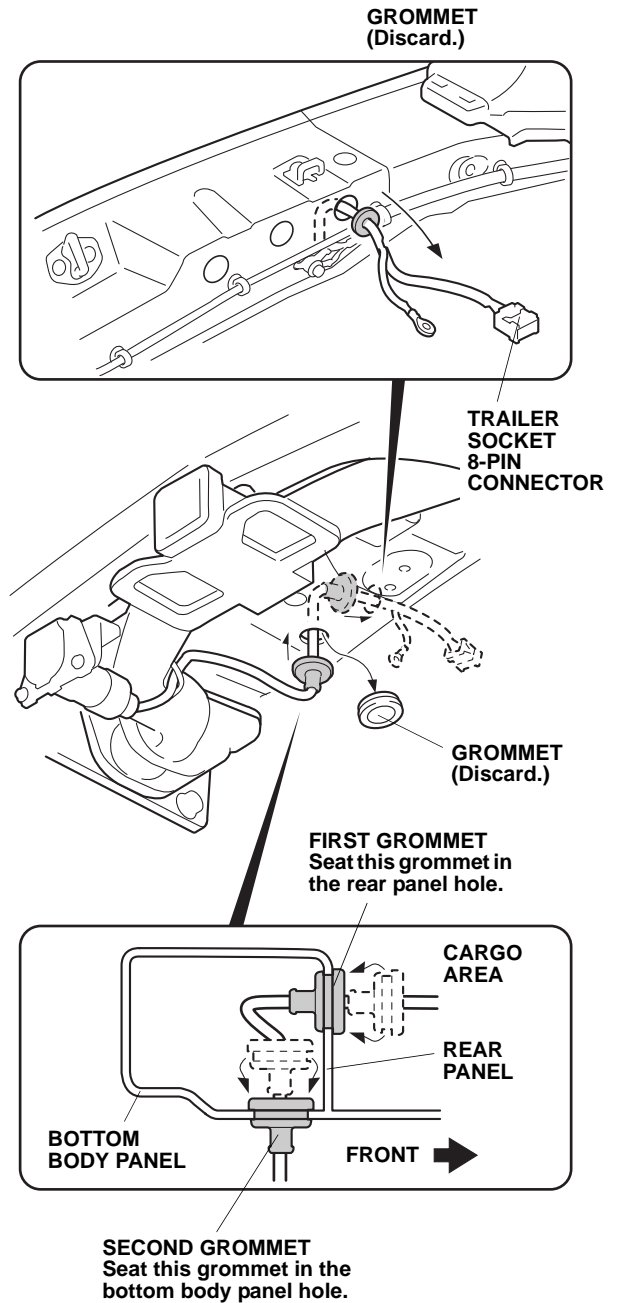

30. Route the trailer socket 8-pin connector up through the hole in the bottom body panel, then through the hole in the rear panel and into the cargo area.
31. Pull the first grommet completely through the hole in the bottom body panel, and seat the first grommet in the rear panel hole. Seat the second grommet in the bottom body panel hole. Take care not to pull too hard on the harness while installing the grommets.

- Remove the vehicle ground bolt, then secure the trailer socket ground terminal using the vehicle ground bolt.

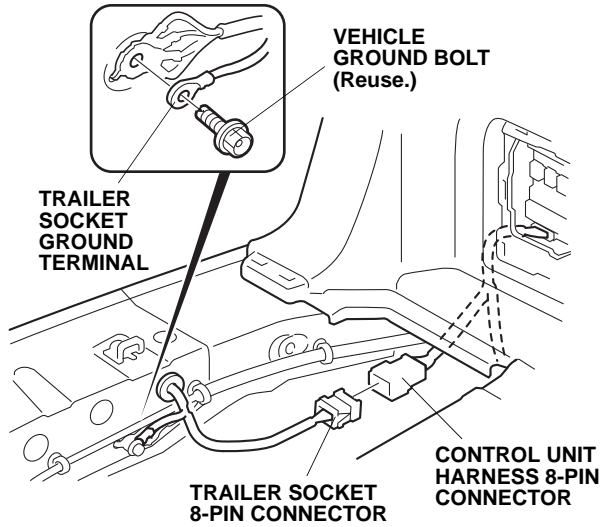

- Plug the control unit harness 8-pin connector into the trailer socket 8-pin connector.
- Secure the trailer socket harness and control unit harness to the vehicle harness with four wire ties in the areas shown.

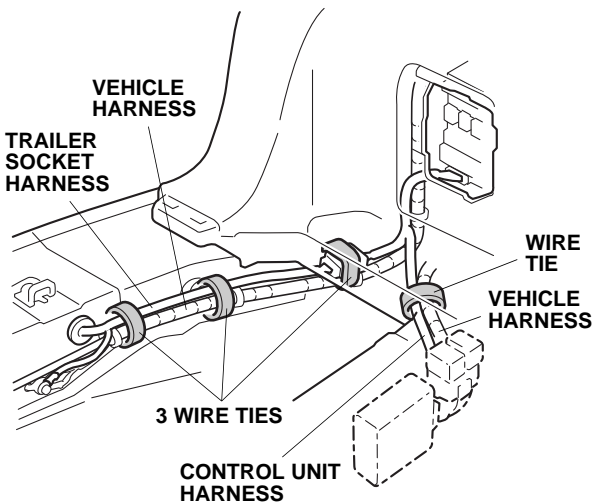

- Reinstall the vehicle control unit.

## Installing the Fuses

- Install the two 20A fuses and the two 7.5A fuses into the slots in the rear fuse box.

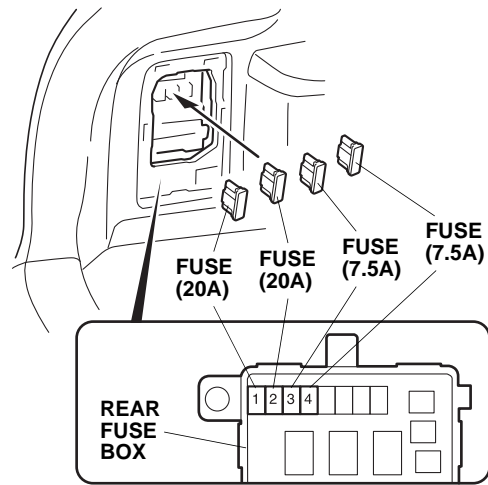

- Open the hood. Locate and open the under hood fuse box lid. Install the 20A fuse into the slot shown in the under hood fuse box. Reinstall the under hood fuse box lid.

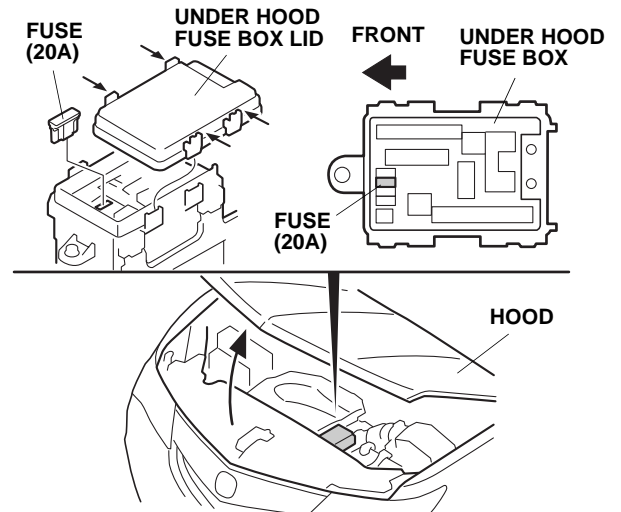

38. Slide the ball mount into the trailer hitch. Align the hole in the trailer hitch with the hole in the ball mount, then insert the hitch pin into the hole. Secure the hitch pin with the hitch pin clip.

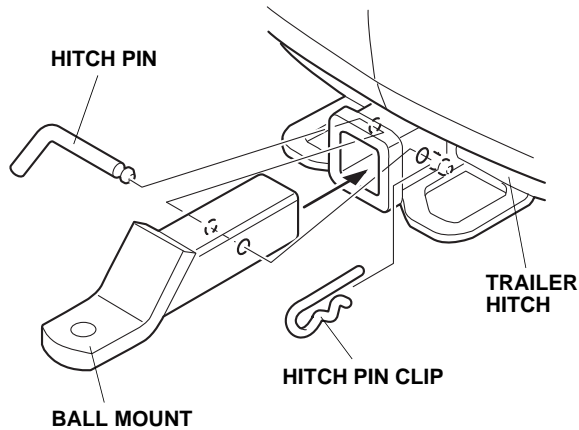

39. Check that all wire harnesses and cables are routed properly and that all connectors are plugged in.
40. Reinstall all removed parts. Check that all clips and fasteners are installed securely.
41. Reconnect the negative cable to the battery. Check that the electrical accessory and other electrical systems function properly.
42. Enter the client's radio anti-theft code, and reset the radio station presets.
43. Reset the clock.
44. Check the operation of the trailer harness according to the Accessory User's Information Manual supplied.

NOTE: After about 620 miles (1,000 km) of towing, recheck the torque of the trailer hitch bolts.

**Put a Copy of this Page in the Glove Box for Your Client**

**Installing the Receiver Cover**

Whenever you remove the hitch pin clip, the hitch pin, and the ball mount, securely store them in the cargo area. Then install the receiver cover into the opening at the end of the trailer hitch. When you reinstall the ball mount, store the receiver cover in the cargo area.

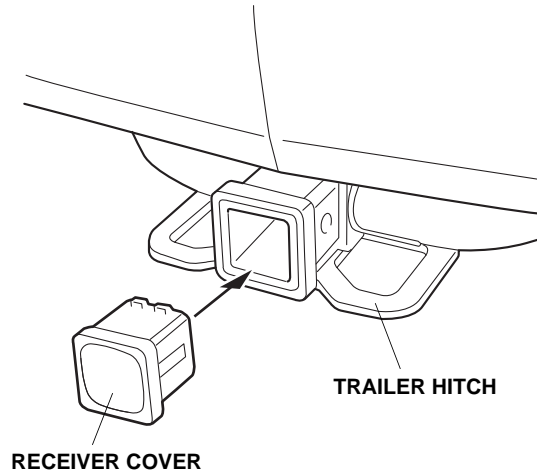

**Subharness for Electric Brake Controller**

This subharness adapts an electric trailer brake controller to your vehicle. Have a qualified technician install your trailer brake controller following the trailer brake controller manufacturer's instructions. For more information, refer to "Towing a Trailer" in your vehicle owner's manual.

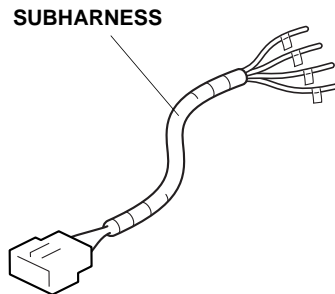

**CIRCUIT DIAGRAM**

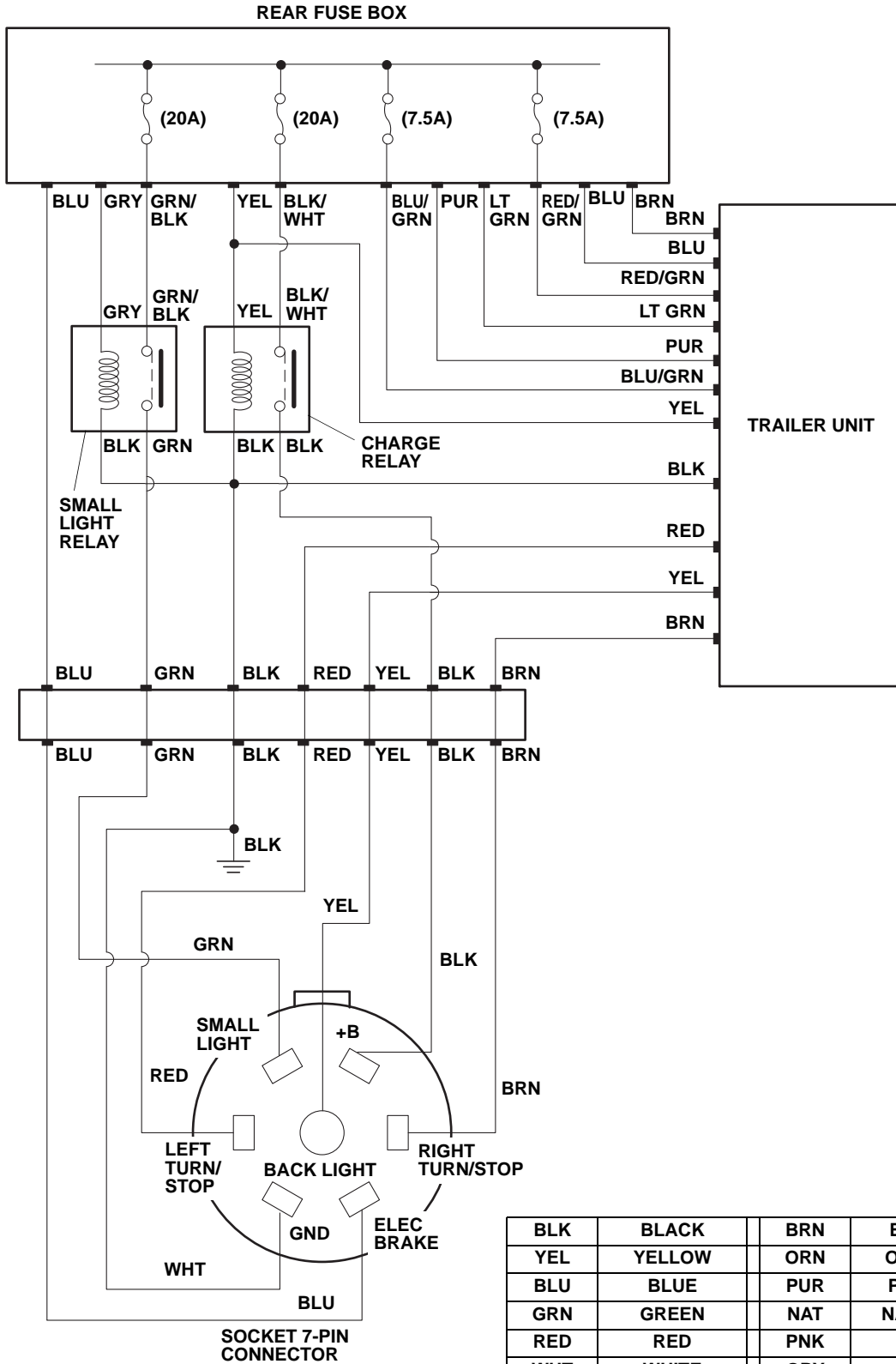

BLK	BLACK	BRN	BROWN
YEL	YELLOW	ORN	ORANGE
BLU	BLUE	PUR	PURPLE
GRN	GREEN	NAT	NATURAL
RED	RED	PNK	PINK
WHT	WHITE	GRY	GRAY
LT BLU	LIGHT BLUE	LT GRN	LIGHT GREEN