

# ACURA INSTALLATION INSTRUCTIONS

Accessory  
**ENGINE BLOCK HEATER  
P/N 08T44-S5B-100**

Application  
**2006 TL**

Publications No.  
**BII 30913**  
Issue Date  
**SEP 2005**

## PARTS LIST

Engine block heater

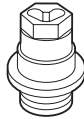

Aluminum washer



Heater harness

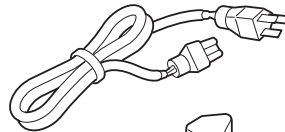

Protective cap

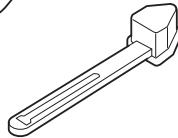

20 Wire ties  
(5 not used)

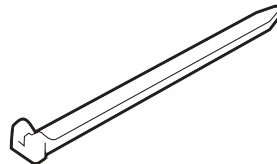

## TOOLS AND SUPPLIES REQUIRED

Phillips screwdriver

Ratchet

19 mm and 24 mm Sockets

Torque wrench

Diagonal cutters

Coolant (Honda All Season Antifreeze/Coolant Type 2)

White marker (or equivalent)

Tape measure

Diagonal cutters

## NOTE

- Always use Honda All Season Antifreeze/Coolant Type 2. Using a non-Honda coolant can result in corrosion, causing the cooling system to malfunction or fail.
- To avoid burning out the element, do not operate the engine block heater before it is installed in the vehicle and before you add coolant.

## INSTALLATION

**Customer Information:** The information in this installation instruction is intended for use only by skilled technicians who have the proper tools, equipment, and training to correctly and safely add equipment to your vehicle. These procedures should not be attempted by "do-it-yourselfers."

1. Allow the engine and all cooling system components to cool down.
2. Place a clean drain pan under the radiator drain plug, then remove the drain plug from the bottom of the radiator to drain the coolant. Remove the radiator cap to increase the flow.

**NOTE:** Radiator coolant will damage paint. Quickly rinse any spilled coolant from painted surfaces.

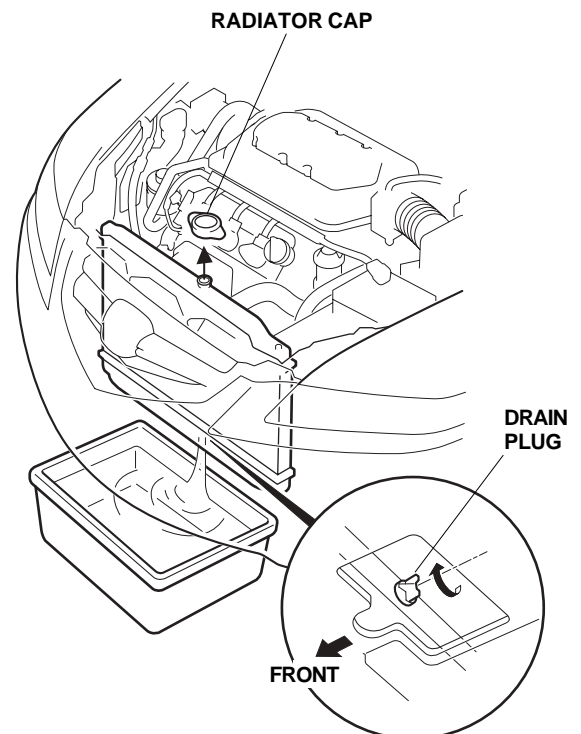

3. Remove the left side engine compartment cover (two pins and one hook).

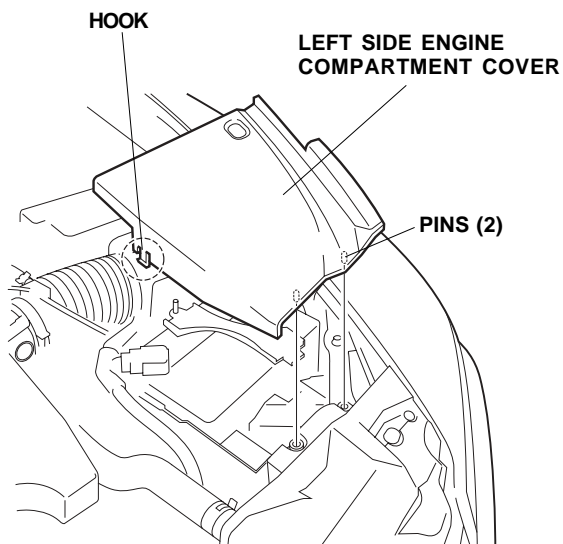

4. Make sure you have the anti-theft codes for the radio and the navigation system (if equipped), then write down the XM radio channel presets. With the ignition switch off, disconnect the negative cable from the battery.
5. Open the positive cable cover, and disconnect the positive cable. Loosen the two nuts, and remove the battery hold down bracket. Remove the battery.

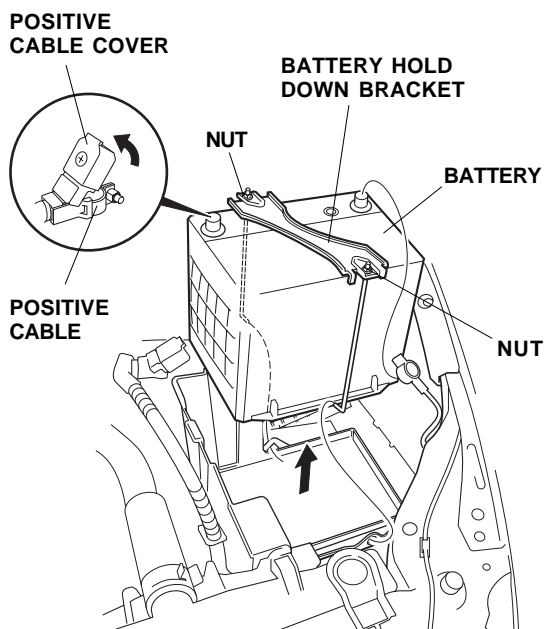

4. Remove the right side engine compartment cover (three pins and three hooks).

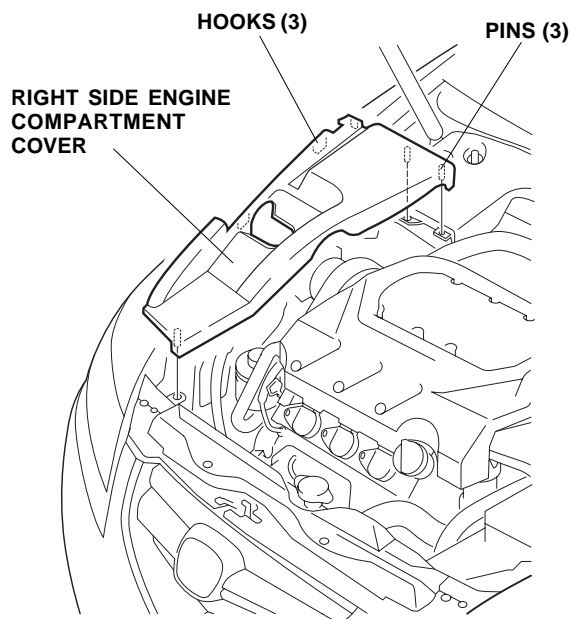

5. Remove the front bulkhead cover (five clips and two pins).

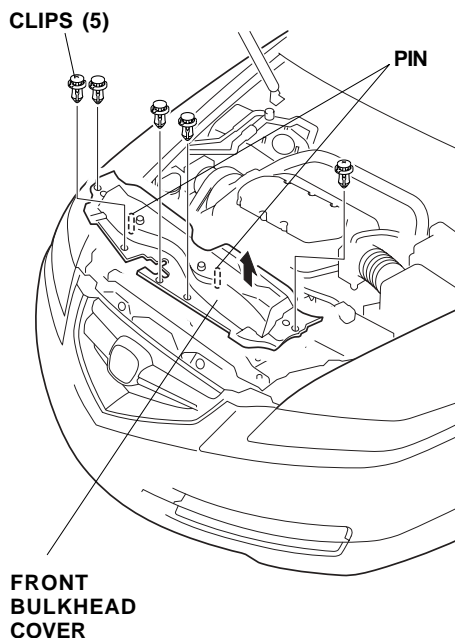

6. Remove the air intake cover (two clips), and remove the air duct.

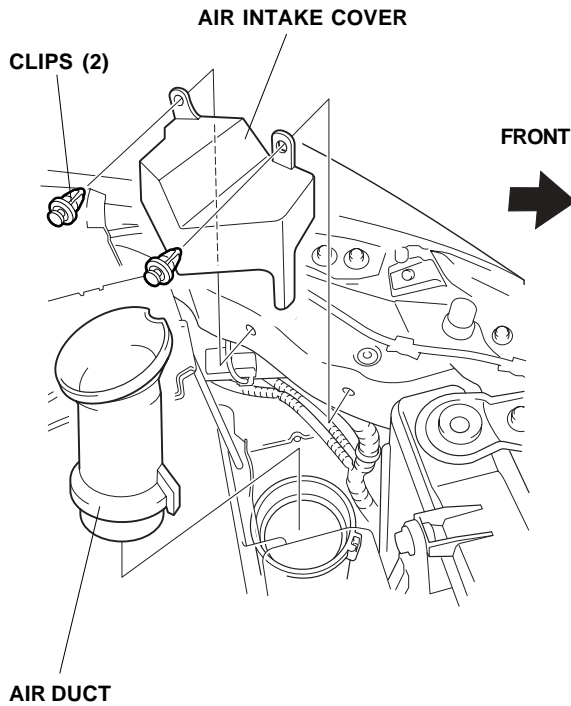

7. Remove the coolant reservoir and coolant reservoir bracket (one bolt).

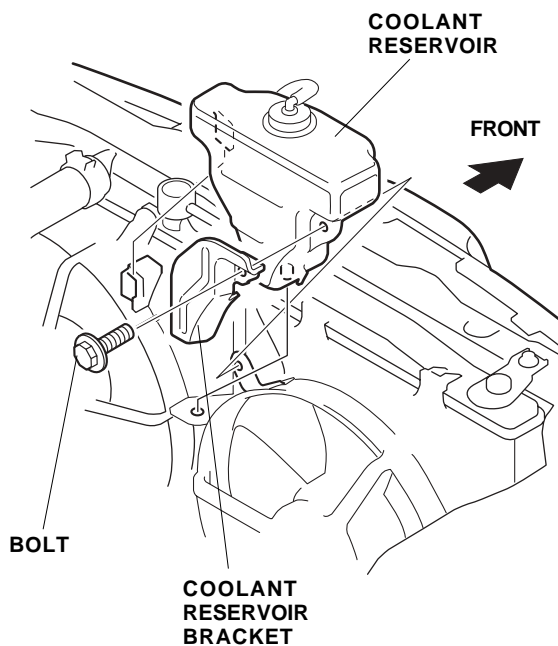

8. Using a 19 mm socket, remove the drain bolt and washer from the left side of the engine block. The coolant remaining in the engine jackets will flow out of the bolt hole when the drain bolt is removed. Retain the bolt; it will be used if the engine block heater is removed.

NOTE: Use a new washer if the drain bolt is reinstalled.

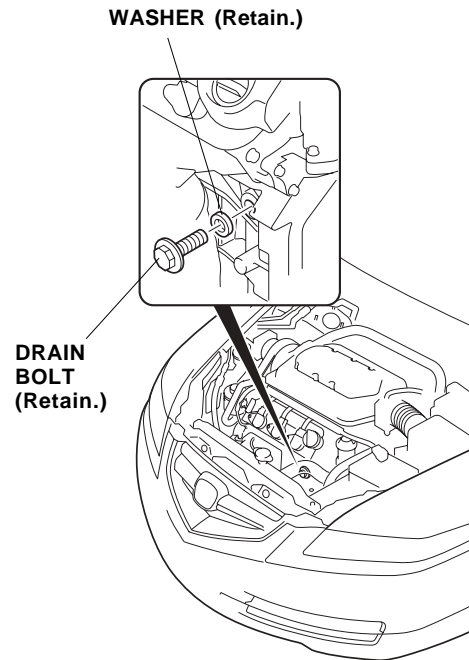

9. Install the engine block heater with the aluminum washer into the hole using a 24 mm socket. Torque the engine block heater to 60 N·m (44 lb-ft).

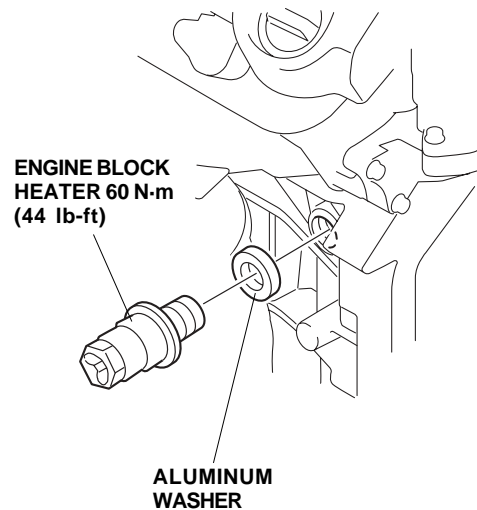

10. Using a tape measure and white marker, measure and mark the heater harness at the measurements as shown.

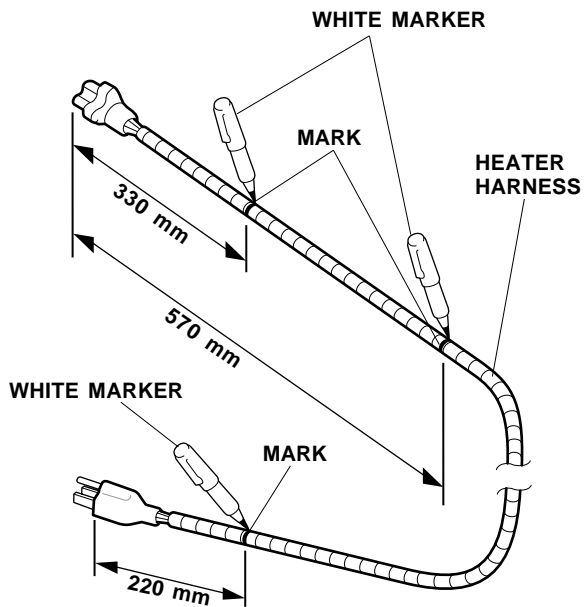

11. Plug the heater harness connector into the engine block heater, and secure the heater harness to the vehicle harness with one wire tie over the white mark.

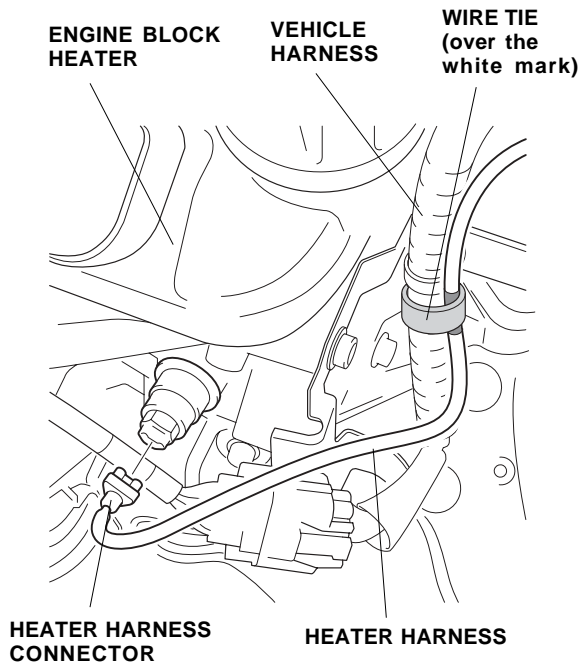

12. Route the heater harness along the fan frame, and attach it to the fan shroud with three wire ties.

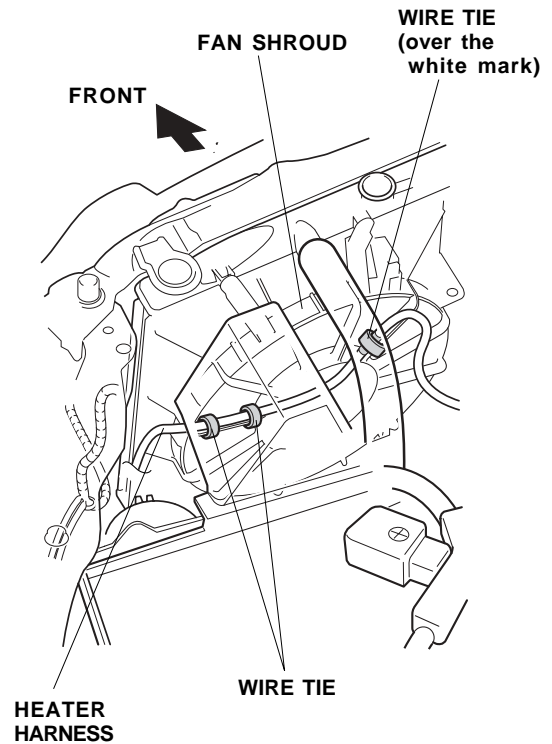

13. Route the heater harness along the vehicle harness through the bulkhead to the left side, and loosely secure it to the vehicle harness with three wire ties.

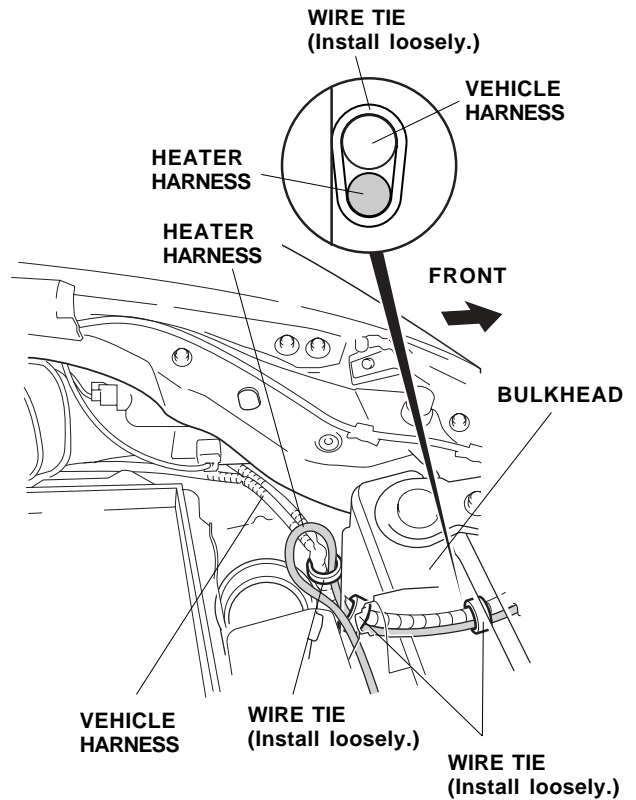

- At the front grille area, measure and cut off a small piece of the bumper grille in the area shown.

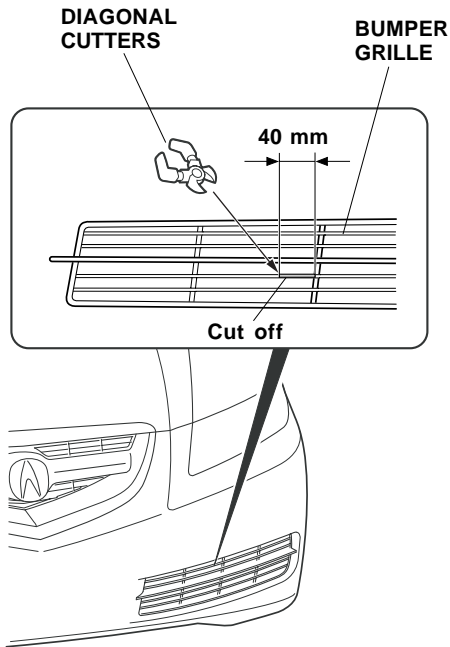

- Route the heater harness through the bumper opening, and secure it to the bumper grille with one wire tie.

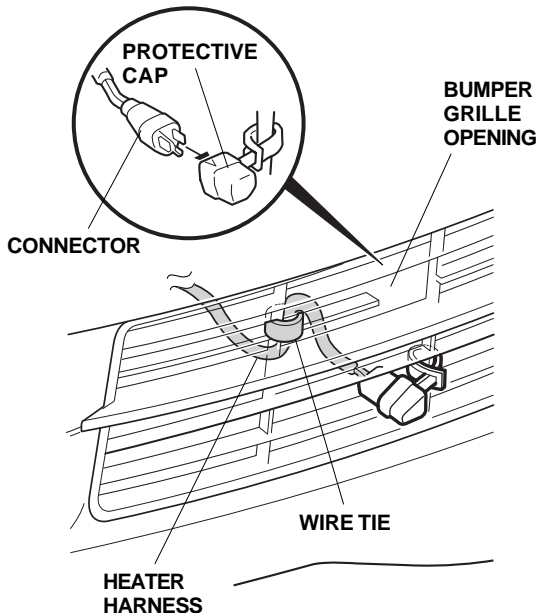

- Attach the protective cap to the bumper grille, and plug the heater harness connector into the protective cap.
- Fold up the excess length of the heater harness, and test fit the air intake cover with the heater harness in place. Secure the heater harness to the vehicle harness with three wire ties.

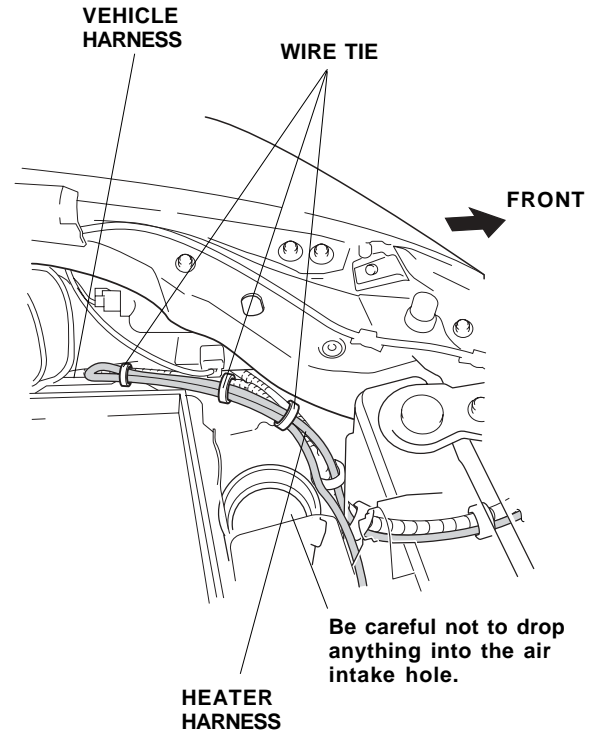

- Tighten the three wire ties loosely installed in step 13.
- Reinstall the radiator drain plug.
- Fill the system with the recommended coolant. Follow the instructions described in the service manual to fill and bleed the cooling system.
- Check the coolant reservoir for correct level and check the cooling system for signs of leakage. Repair as necessary.
- Check that the heater harness is routed properly and all of the connectors are plugged in.
- Reinstall all removed parts.
- Enter the radio and navigation system (if equipped) anti-theft code(s), and set the XM radio channel presets.
- Set the clock (without navigation system).
- Give the drain bolt (removed in step 8) to you customer.