



INSTALLATION INSTRUCTIONS

Accessory

BACK-UP SENSORS

Application

2009 TSX

Publications No.

BII 38589

Issue Date

APRIL 2008

PARTS LIST

Back-up Sensors Attachment Kit P/N 08V67-TL2-200A

Control unit

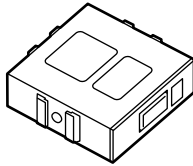

Buzzer

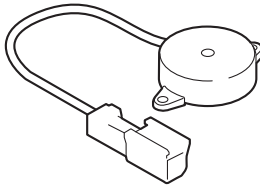

4 Sensor clips

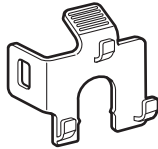

Sensor harness

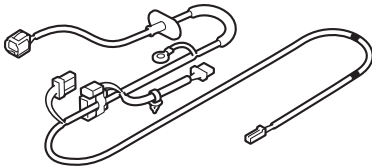

Sub harness

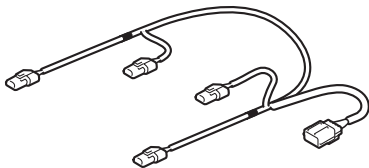

Control unit

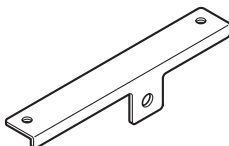

10 Wire ties

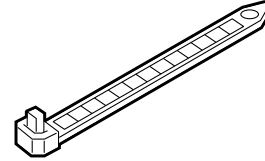

2 Wire ties with clip

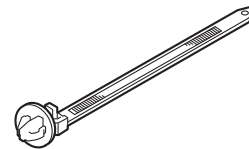

Urethane tape

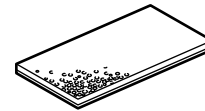

Cushion tape

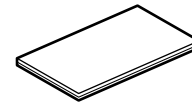

2 Flange bolts



Fuse label

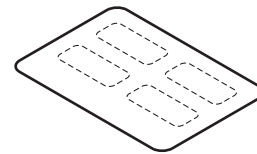

Connector clip



3 Harness tapes

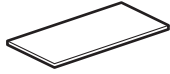

Accessory User's Information Manual

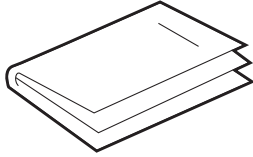

Back-up Sensors Kit

2 Center sensors

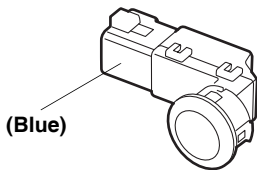

2 Corner sensors

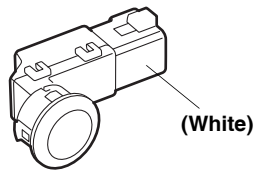

TOOLS AND SUPPLIES REQUIRED

- Phillips screwdriver
- Flat-tip screwdriver
- Small flat-tip screwdriver
- Ratchet
- 8 mm and 10 mm Socket
- Tape measure
- Utility knife
- Felt-tip pen
- Pushpin
- Drill
- 3 mm Drill bit
- 24 mm and 26 mm Hole saw
- Eye protection (safety goggles, face shield, etc.)
- File
- Diagonal cutters
- Isopropyl alcohol
- Shop towel
- Plastic Trim Tool (T/N SILTRIMTL10)
- Blanket

Illustration of the Back-up Sensors Installed on the Vehicle

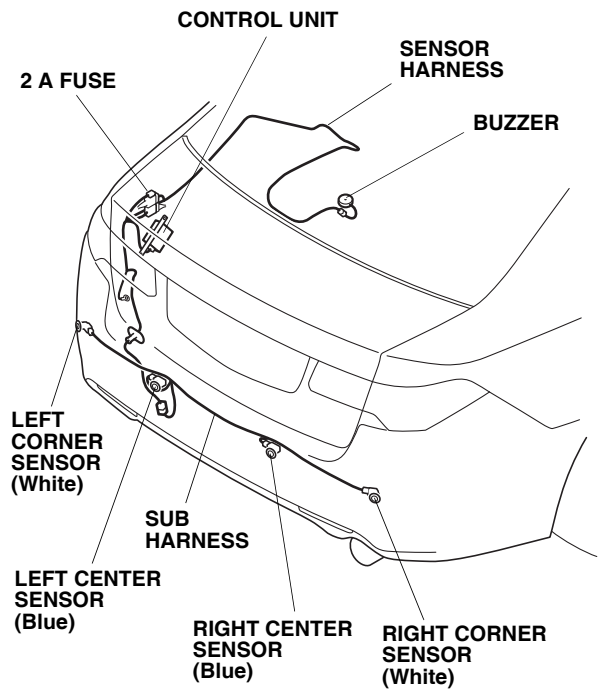

INSTALLATION

Client Information: The information in this installation instruction is intended for use only by skilled technicians who have the proper tools, equipment, and training to correctly and safely add equipment to your vehicle. These procedures should not be attempted by "do-it-yourselfers."

1. Make sure you have the anti-theft code for the audio system or the navigation system (if equipped), then write down the radio presets.
2. Disconnect the negative cable from the battery.

- Open the trunk lid, and remove the two caps and two bolts from the rear bumper.

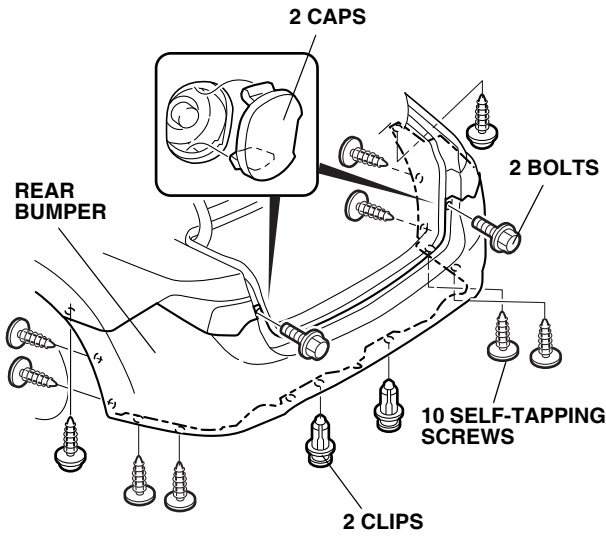

- Remove the rear bumper.
 - Have an assistant help you when removing and installing the rear bumper.
 - Place the rear bumper on the blanket to prevent damage.

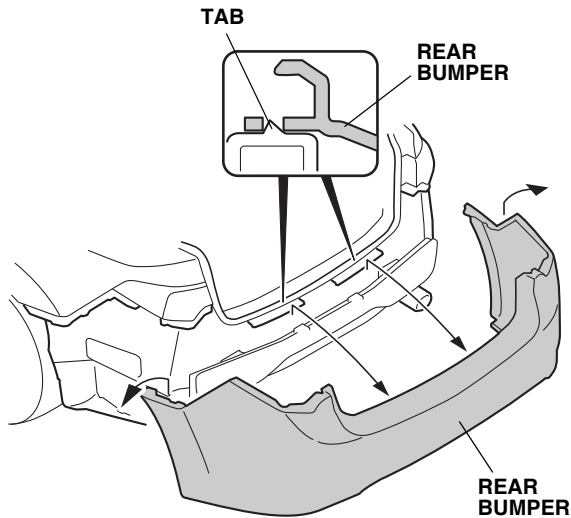

- Pull the left and right rear seatback lock openers to tilt the left and right rear seatbacks forward.

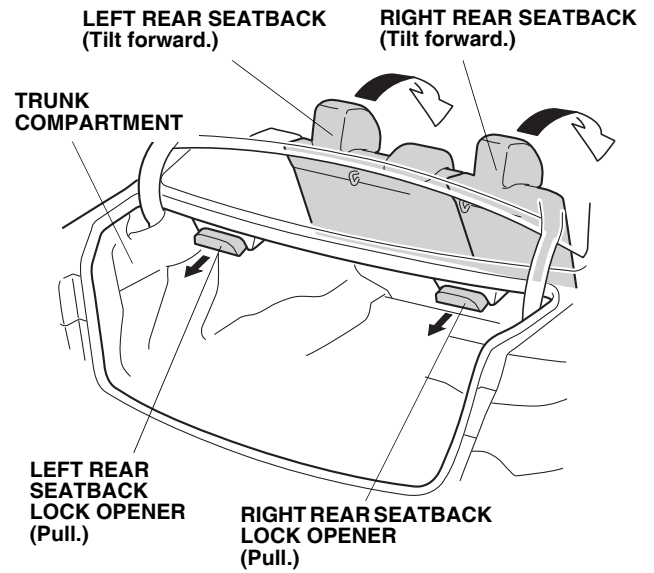

- Remove the spare tire lid (two clips).

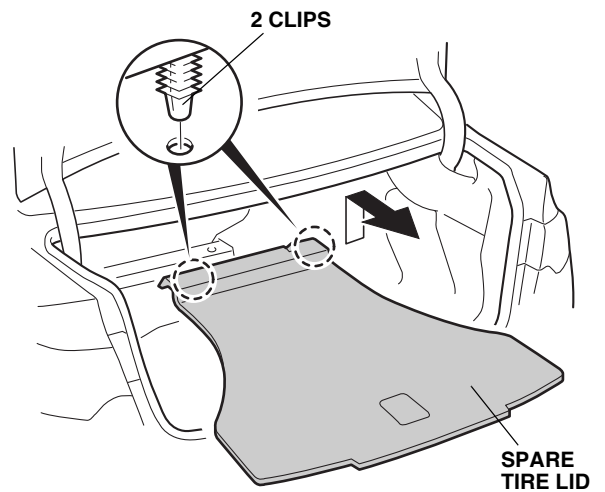

7. Pull away the weatherstrip, and remove the rear trim panel (five clips and two hooks).

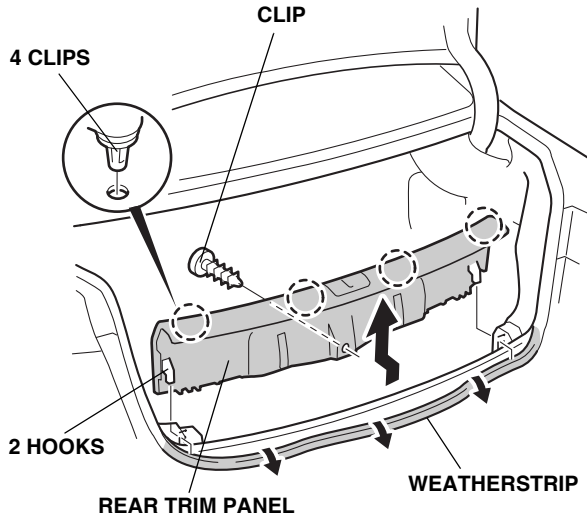

8. Pull away the weatherstrip, and remove the left trunk side trim panel (five clips and two hooks).

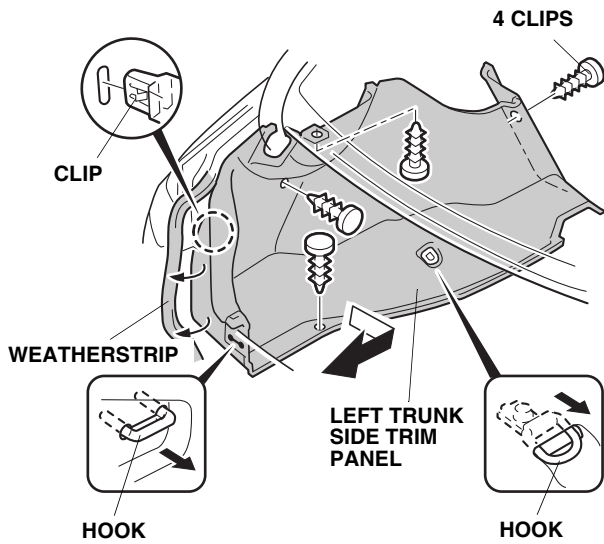

9. Attach the 2 A rear sensor fuse label to the sensor harness fuse case.

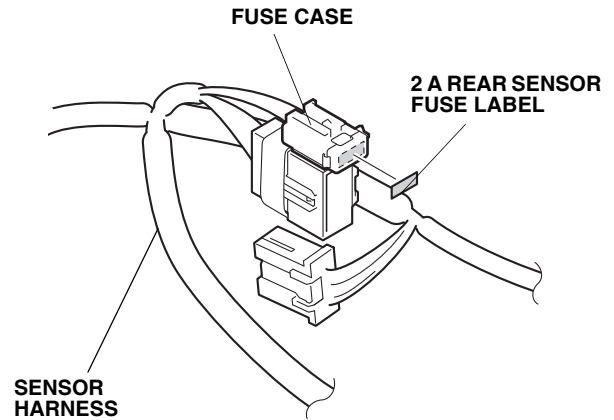

10. Route the sensor harness 14-pin connector through the vehicle panel as shown.

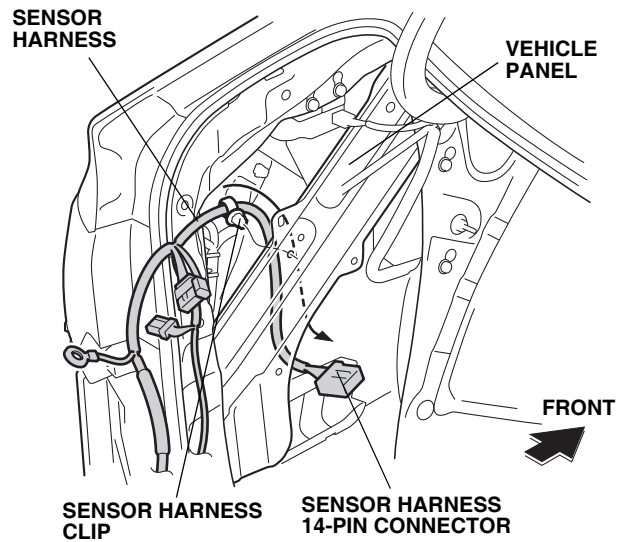

11. Secure the sensor harness clip to the vehicle panel.

12. Insert the control unit bracket into the control unit.

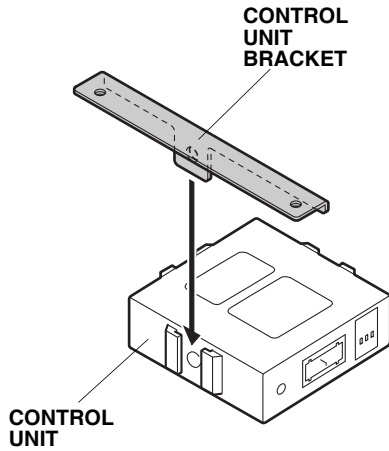

13. Plug the sensor harness 14-pin connector into the control unit.

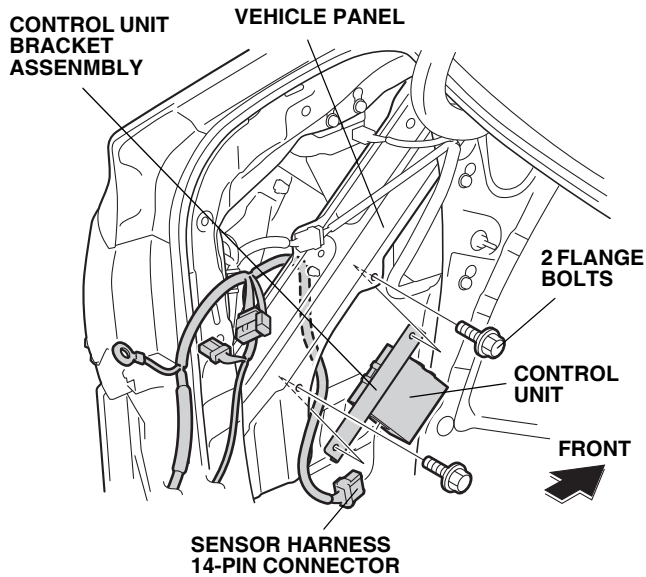

14. Install the control unit bracket assembly on the vehicle panel using two flange bolts.

15. Disconnect the vehicle 20-pin connector. Plug the sensor harness 20-pin connector into the vehicle 20-pin connector. Plug the vehicle 20-pin connector you just disconnected into the sensor harness 20-pin connector.

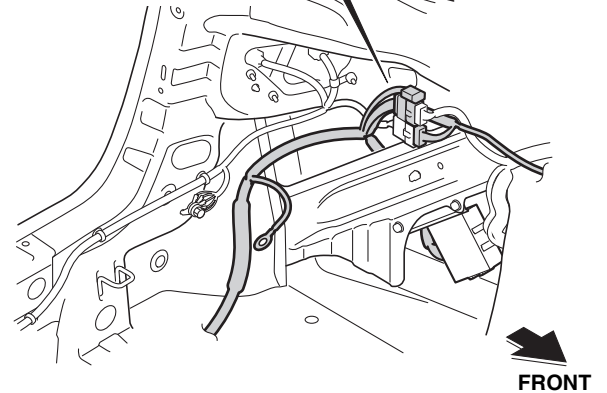
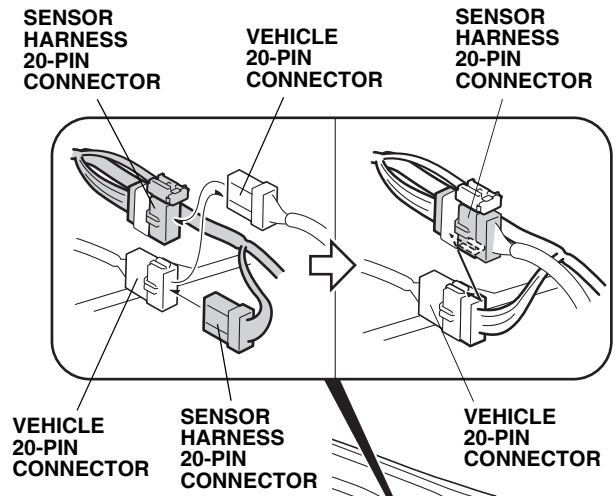

16. Attach the sensor harness 20-pin connector onto the vehicle 20-pin connector as shown.

- Using isopropyl alcohol on a shop towel, clean the area where the buzzer will attach.

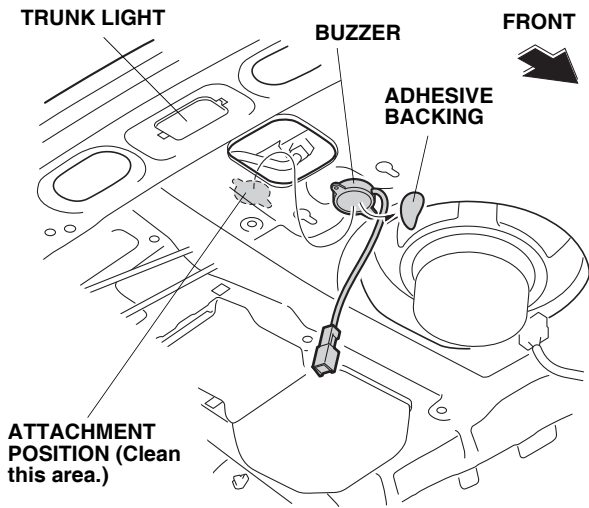

- Remove the adhesive backing from the buzzer, and attach the buzzer at the indicated position.
- Route the sensor harness through the hole in the vehicle panel as shown.

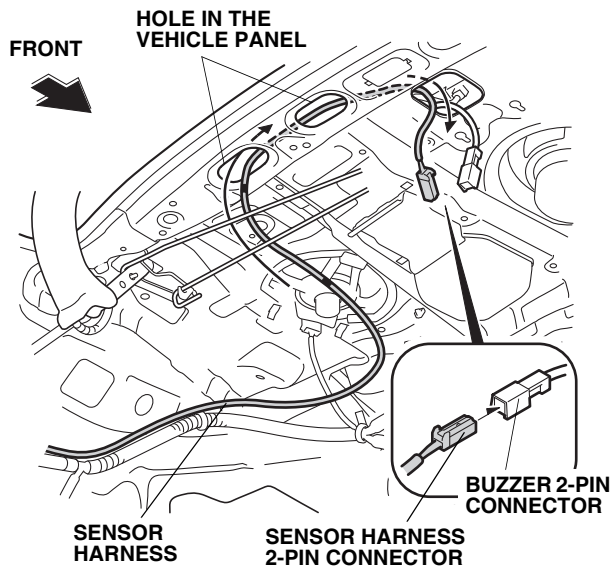

- Plug the sensor harness 2-pin connector into the buzzer 2-pin connector.

- Install one wire tie with clip to the sensor harness at each taped mark.

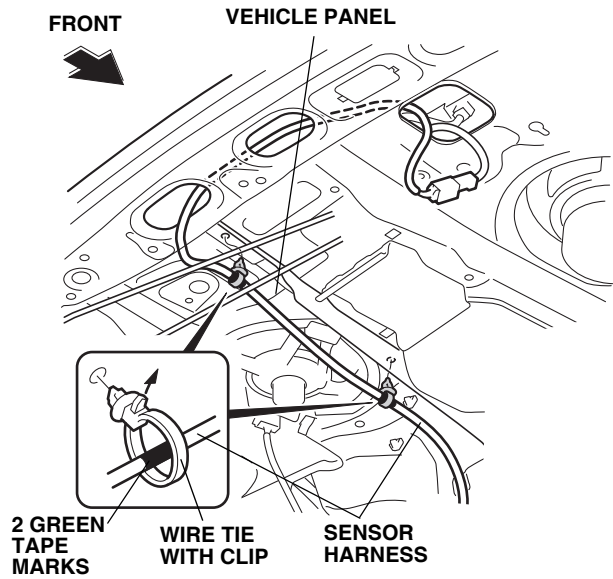

- Secure the sensor harness to the vehicle panel using two wire ties with clips you just installed.
- Using isopropyl alcohol on a shop towel, clean the area where the cushion tape will attach.

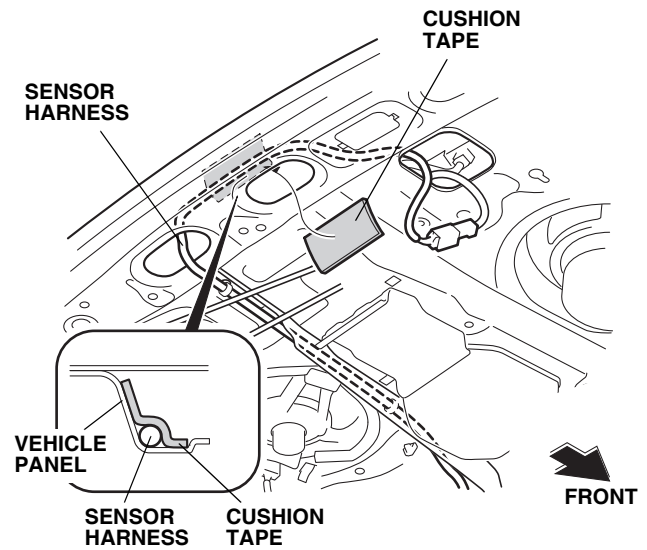

- Secure the sensor harness to the vehicle panel using one cushion tape.

25. Bundle up the excess buzzer harness and secure it to the vehicle harness with one urethane tape.

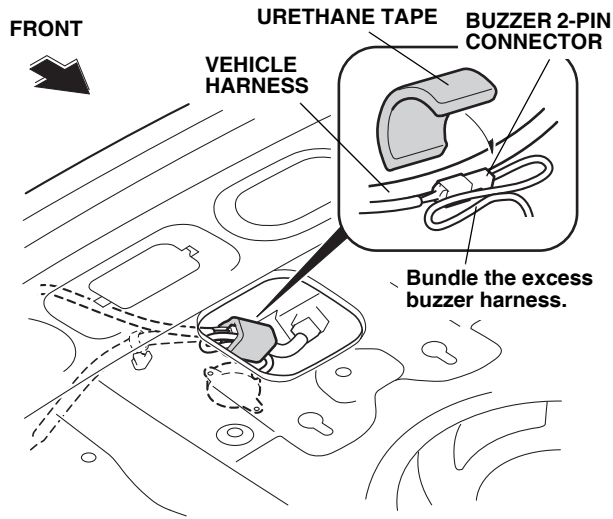

26. Secure the sensor harness to the vehicle harness using six wire ties.

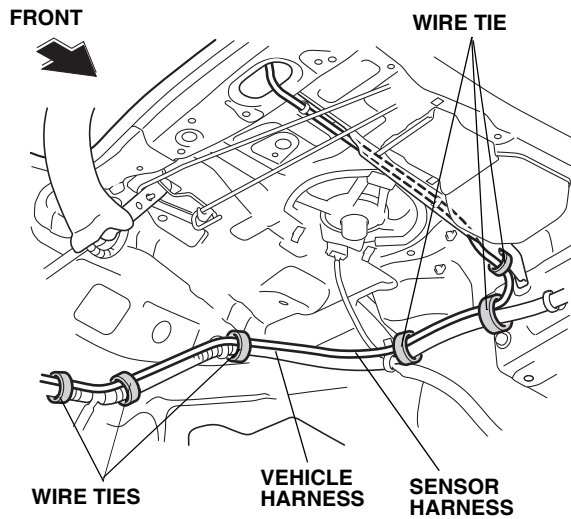

27. Remove the vehicle bolt from the vehicle ground terminal.

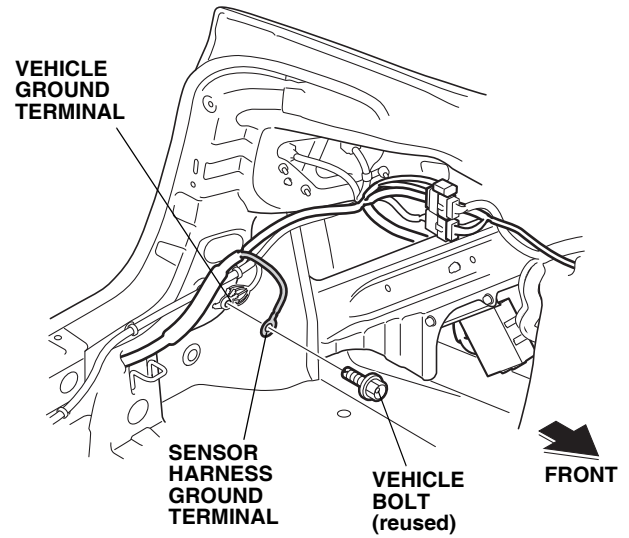

28. Attach the sensor harness ground terminal to the vehicle ground terminal, and reinstall the vehicle bolt.

29. Remove and discard the vehicle grommet.

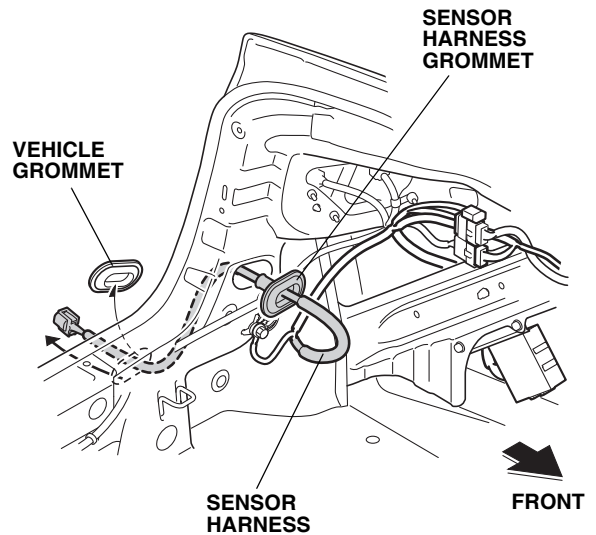

30. Route the sensor harness through the inside of vehicle panel and pull the sensor harness grommet out of the grommet hole.

31. Turn the triangle mark on the sensor harness grommet so it points up, and install the grommet into the vehicle panel as shown.

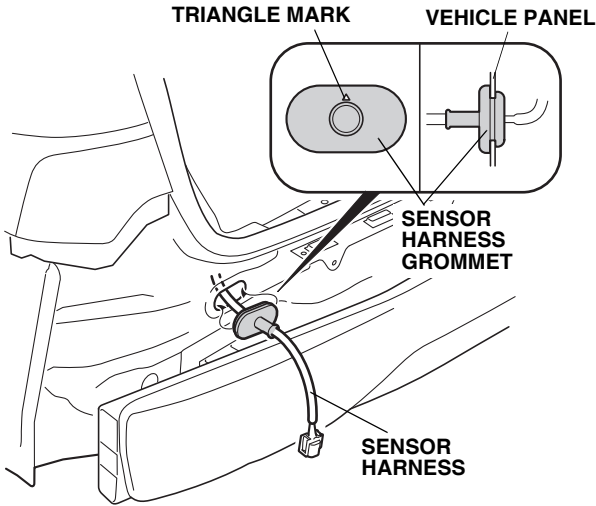

32. Secure the sensor harness to the vehicle harness using two wire ties.

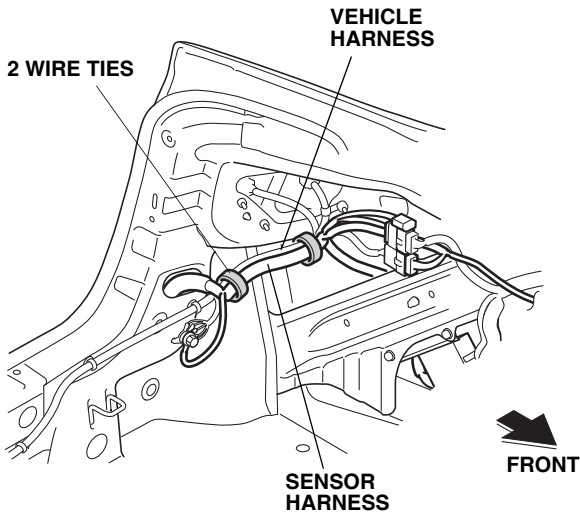

33. Install the connector clip to the sensor harness 8-pin connector, and secure the connector clip to the vehicle panel.

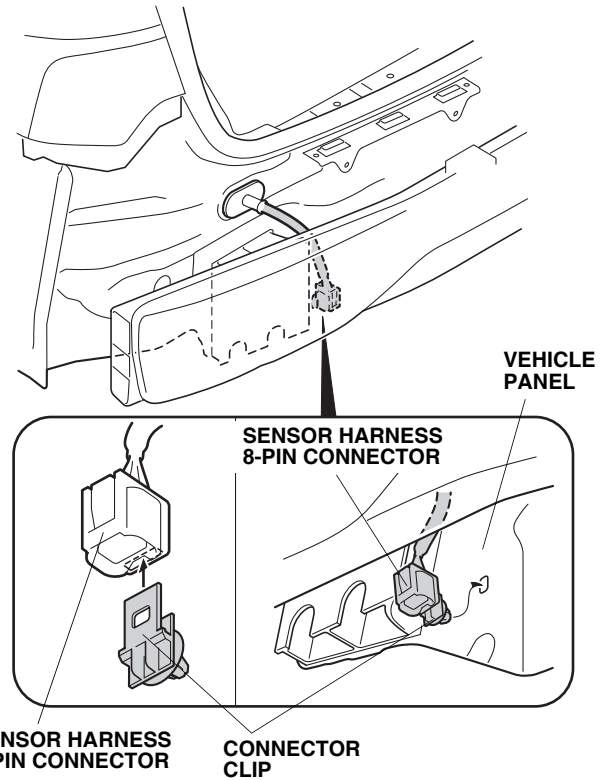

34. Remove the rear bumper absorber from the rear bumper beam.

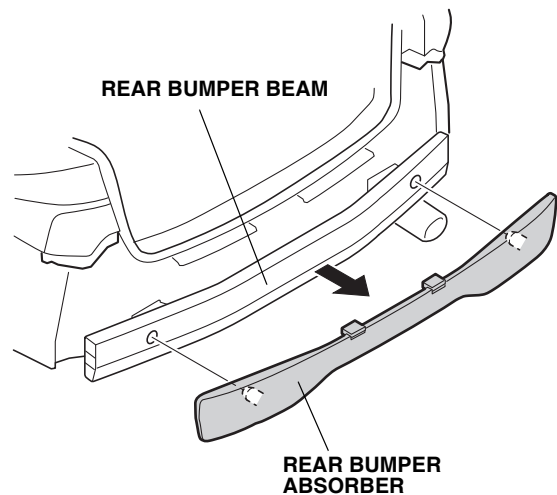

35. Using a utility knife, cut the rear bumper absorber at the measurements shown.

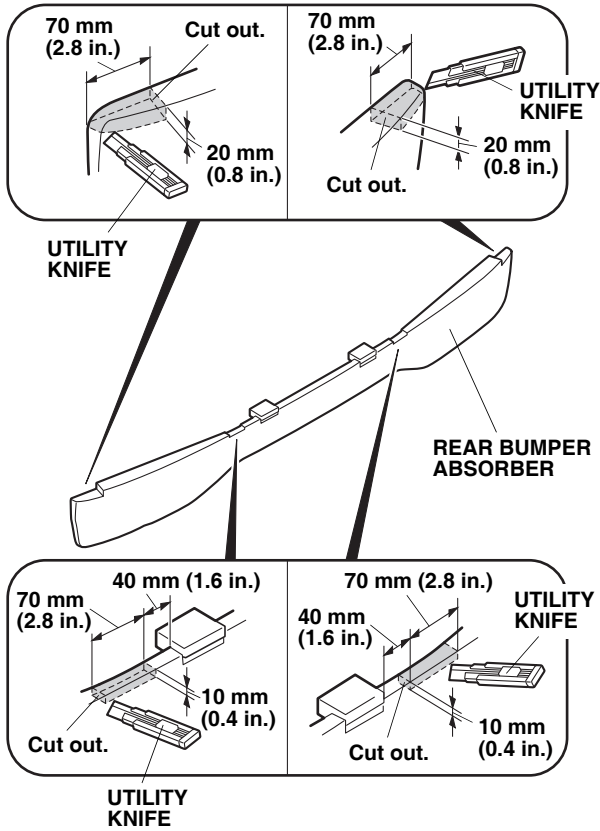

36. Reinstall the rear bumper absorber.

If the vehicle is equipped with an Aero Bumper, go to step 46; otherwise, continue with step 37.

37. Mark the rear bumper:

- On the inside of the bumper, locate the four back-up sensor preset marks. Make sure the marks look like the marks in the illustration below.
- Using a grease pencil, highlight the four preset marks.

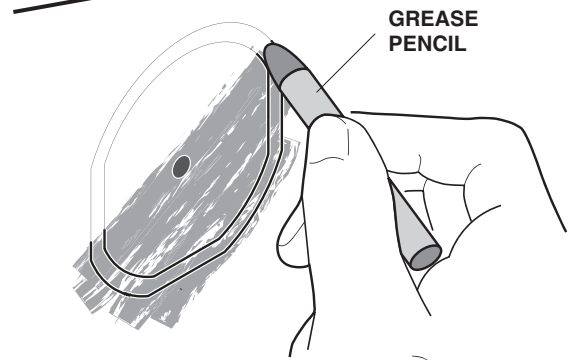
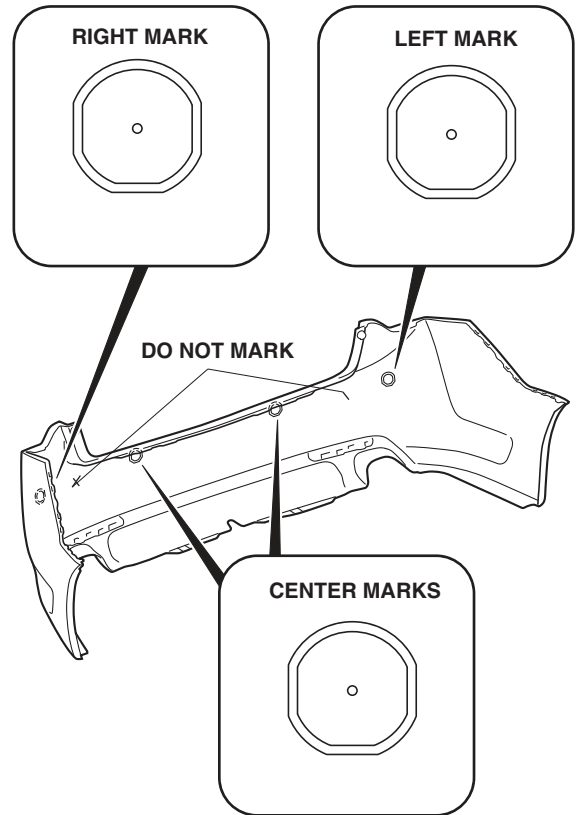

- Locate the center mark protruding from the bumper at each of the four preset marks.
- Using a pushpin, pierce the bumper at all four identified marks.

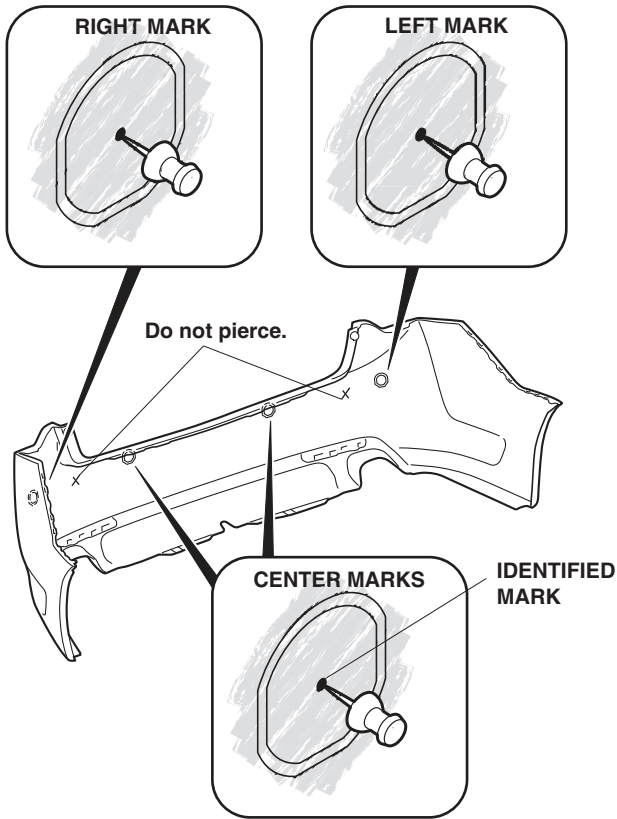

- On the left side of the bumper, use a straight edge to measure 12 mm **upward** from the center mark, and pierce the bumper.

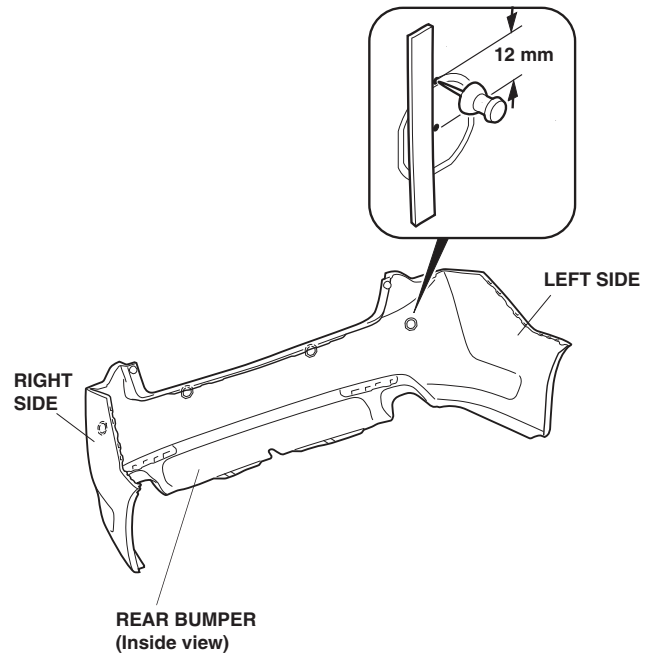

- On the right side of the bumper, use a straight edge to measure 12 mm **downward** from the center mark, and pierce the bumper.

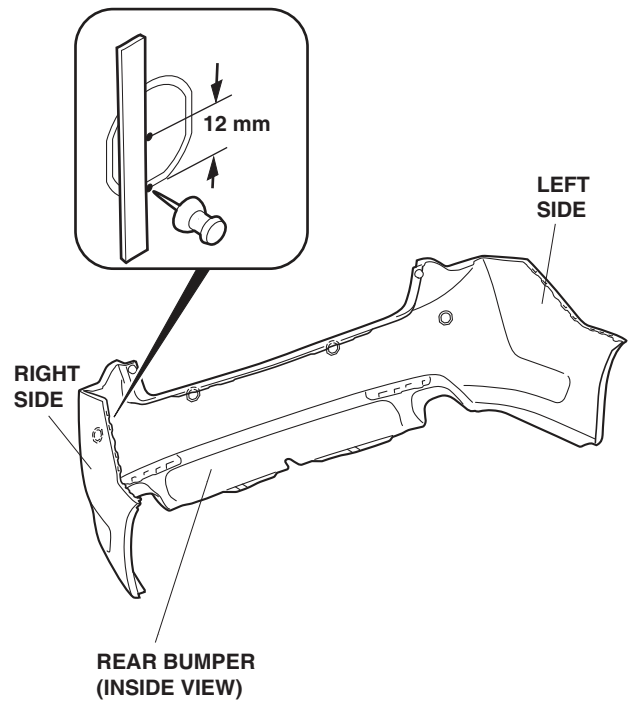

- For the two **center marks** on the bumper, use a straight edge to measure 13 mm **upward**, and pierce the bumper.

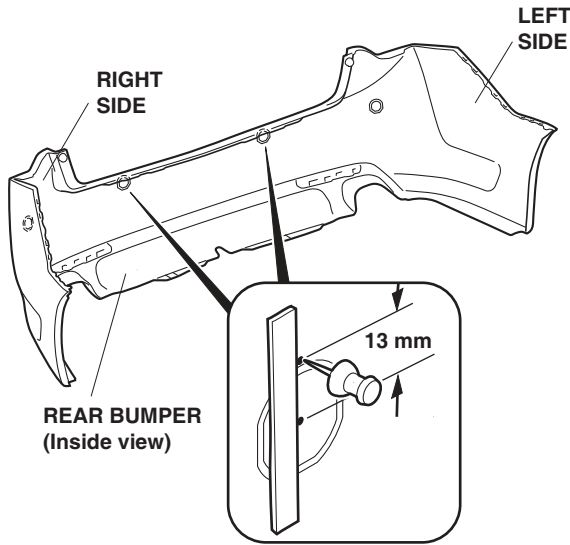

- On the **right side** of the bumper, drill the **lower hole** using a 3 mm bit, and drill the **upper hole** using a 24 mm hole saw.

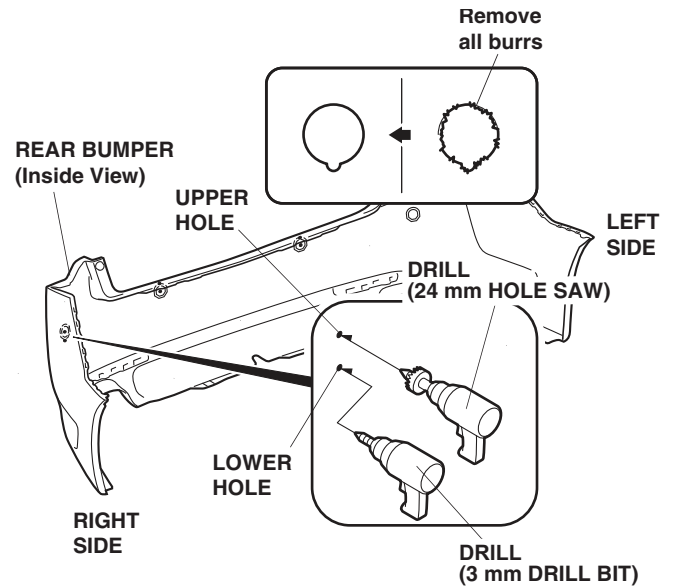

38. While wearing eye protection, drill the rear bumper:

NOTE:

- All holes are drilled from the inside of the bumper.
- The center sensors require a 26 mm hole and corner sensors require a 24 mm hole saw.
- On the **left side** of the bumper, drill the **upper hole** using a 3 mm bit, and drill the **lower hole** using a 24 mm hole saw.

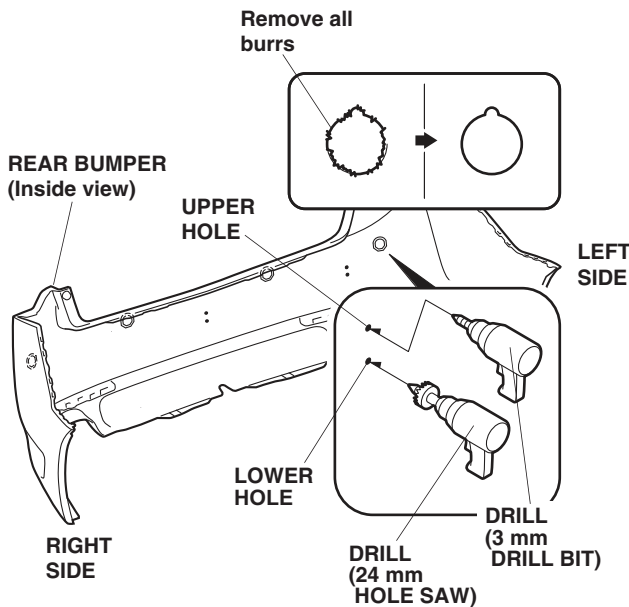

- For the center holes in the bumper, drill the **upper holes** using a 3 mm drill bit, and drill the **lower hole** using a 26 mm hole saw.

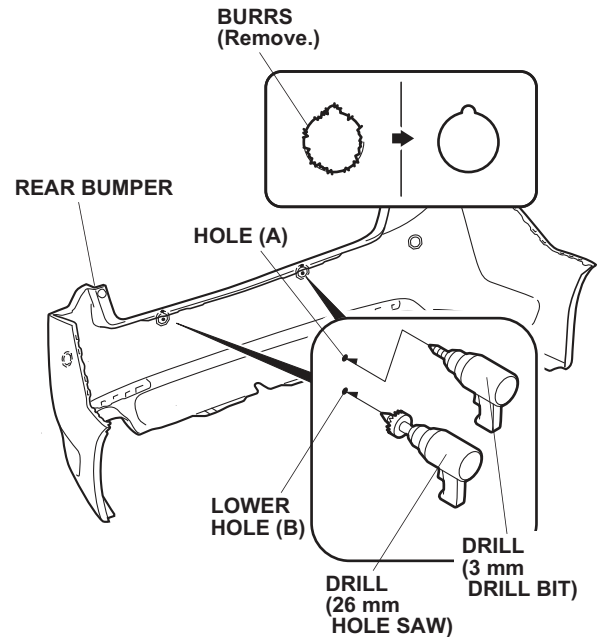

- Remove all burrs from each drilled hole.

39. Install the two corner sensors on the rear bumper using the two sensor clips as shown.

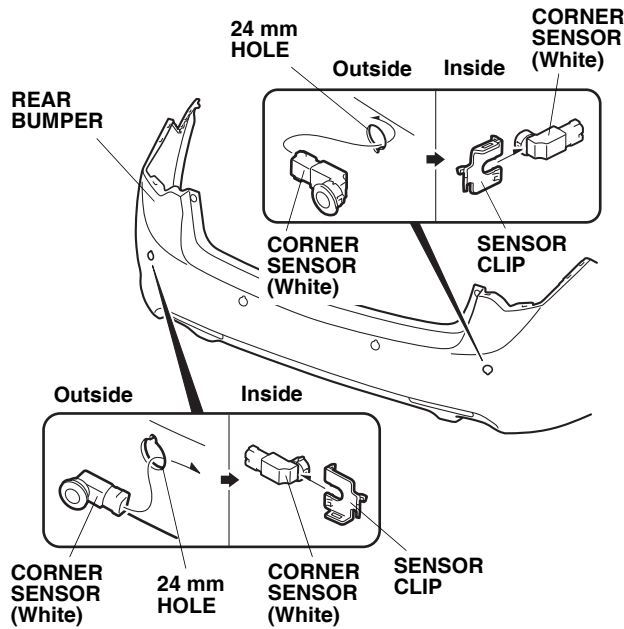

40. Install the two center sensors on the rear bumper using the two sensor clips as shown.

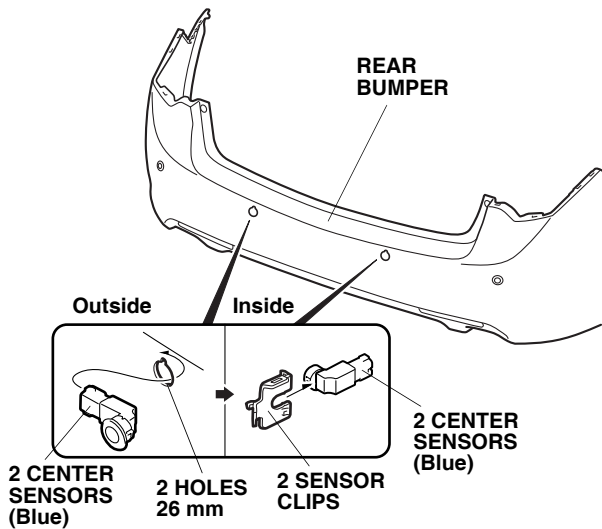

41. Plug in the four sub harness 2-pin connectors to the left center sensor and the right center sensor and the two corner sensors.

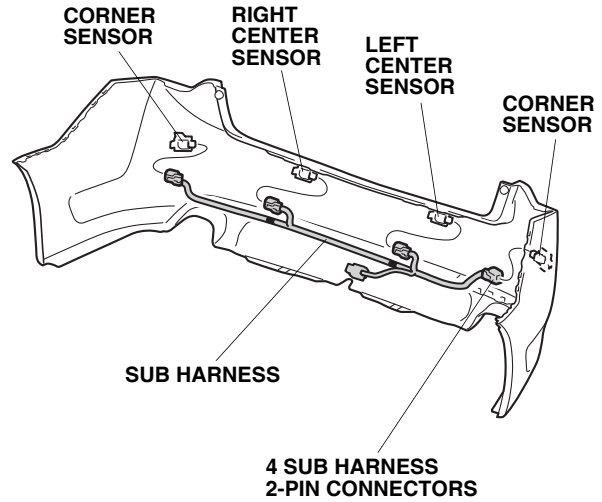

42. Align the two green tapes of the sub harness with the holes of the left center sensor clip and the right center sensor clip, and secure the sub harness to the left center sensor clip and the right center sensor clip using two wire ties as shown.

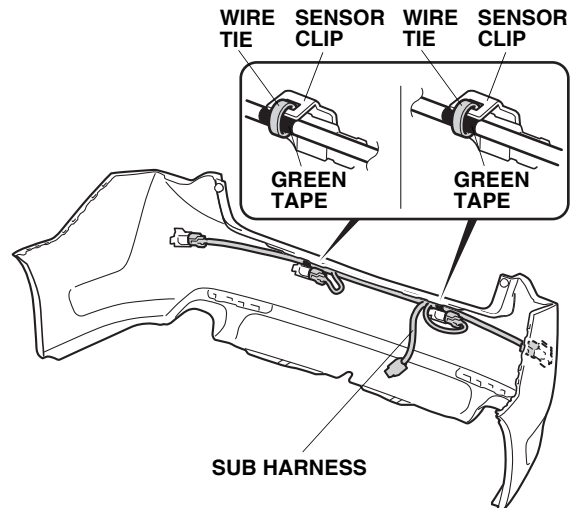

43. Using isopropyl alcohol on a shop towel, clean the area where the harness tape will attach.
44. Attach the sub harness to the rear bumper with three harness tapes.

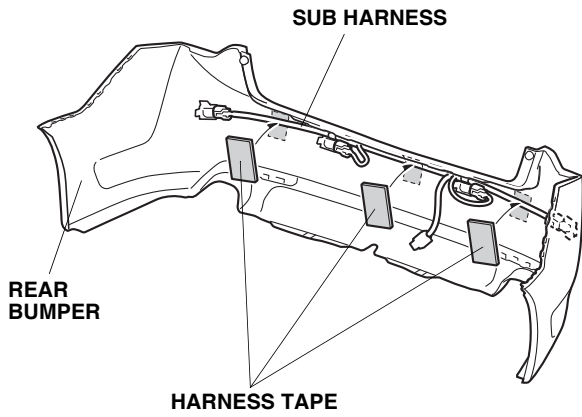

45. With the help of an assistant, bring the rear bumper close to the vehicle. Plug the sub harness 8-pin connector into the sensor harness 8-pin connector, and install the rear bumper in the original position.

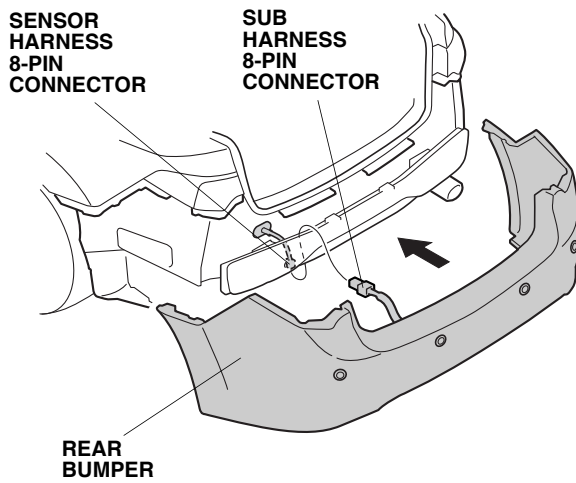

If the vehicle is equipped with an AERO bumper continue with step 46, otherwise go to step 65.

Illustration of the Preset Marks on the Rear Aero Bumper

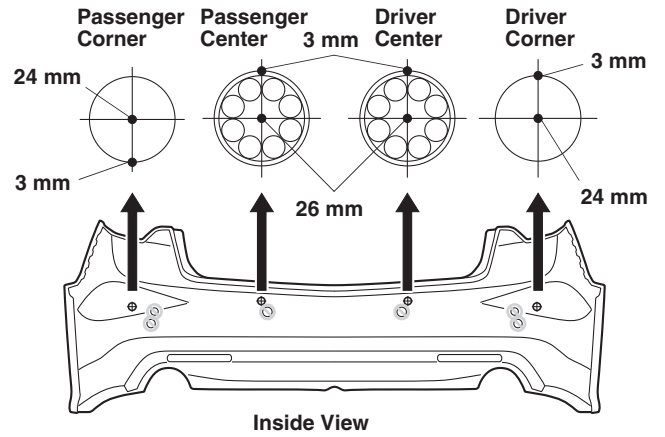

46. Mark the rear Aero bumper:

- On the inside of the bumper, locate the four back-up sensor preset marks. There are several marks on the inside of the bumper, make sure the marks look like the marks in the illustration on page 13.
- On the **right side** of the bumper, pierce the **center** and the **bottom** scribe mark.

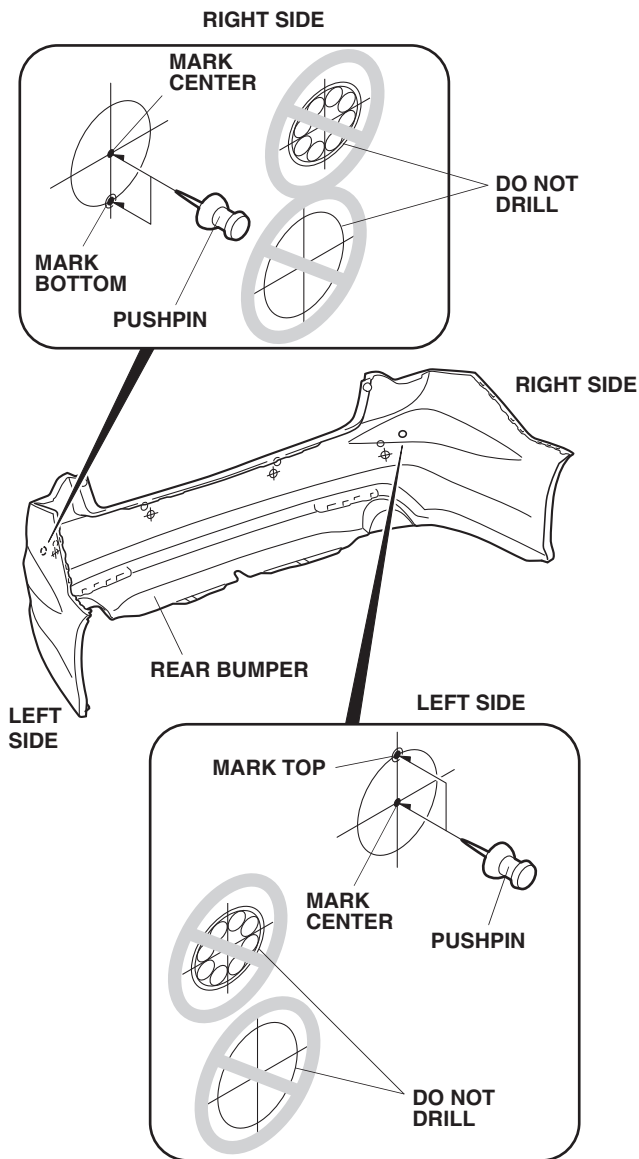

- On the **left side** of the bumper, pierce the **center** and the **top** of the scribe mark.

- For the two **center marks** on the bumper, pierce the center and the **top** of the scribe marks.

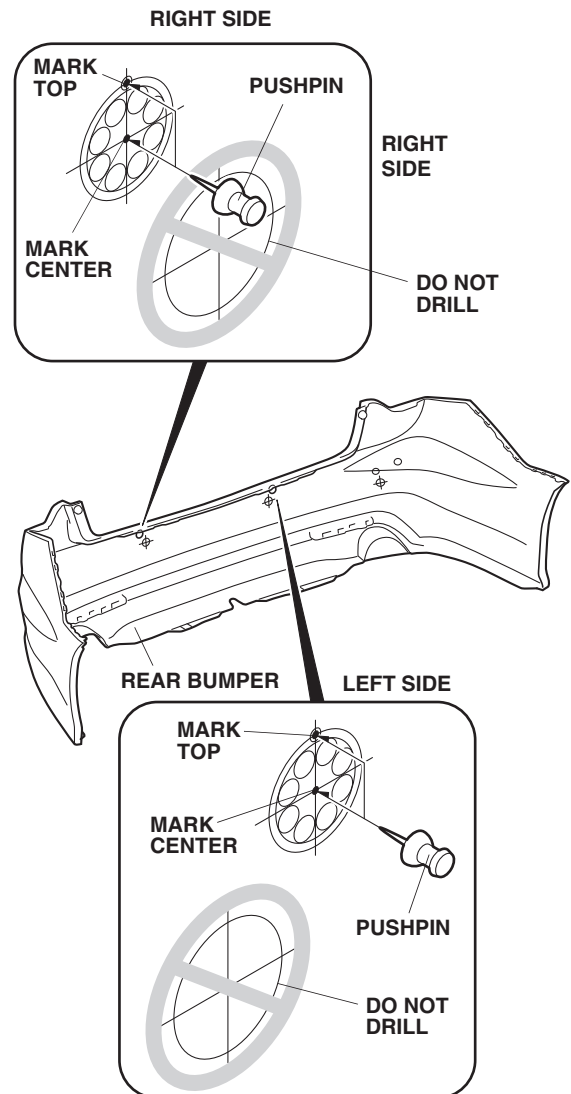

47. While wearing eye protection, drill the rear bumper. All holes are drilled from the inside of the bumper.
- On the **left side** of the bumper, drill the **upper hole** using a **3 mm drill bit**, and drill the **lower hole** using a **24 mm hole saw**.

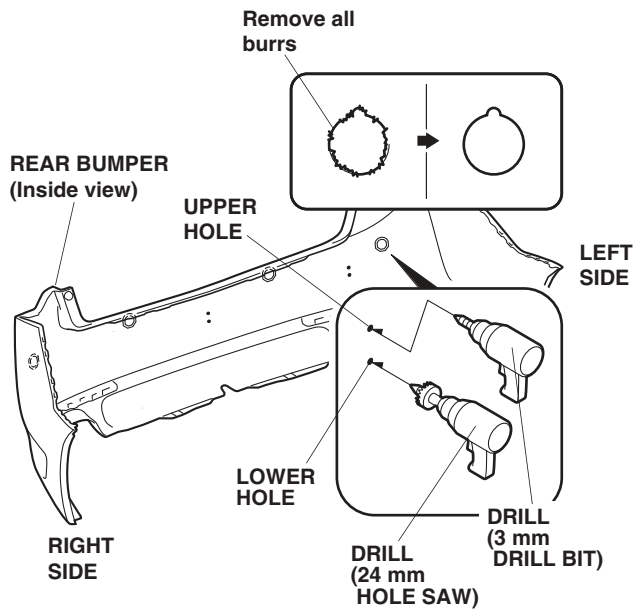

- On the **right side** of the bumper, drill the **lower hole** using a 3 mm bit, and drill the **upper hole** using a **24 mm hole saw**.

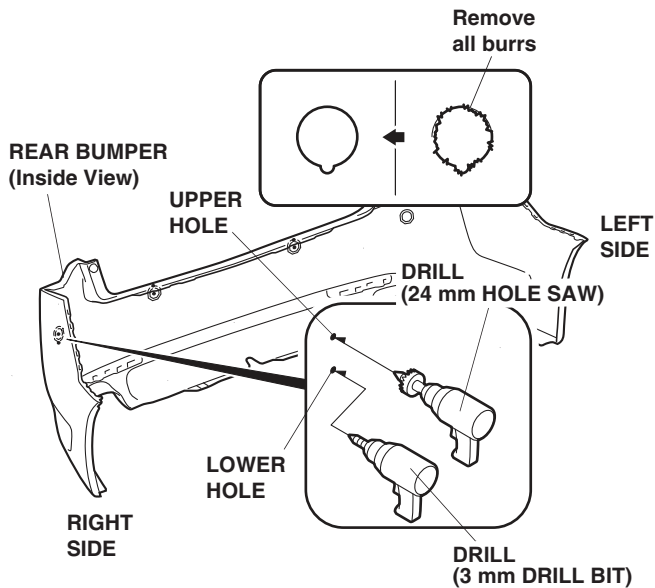

- For the center holes in the bumper, drill the **upper holes** using a **3 mm drill bit**, and drill the **lower hole** using a **26 mm hole saw**.

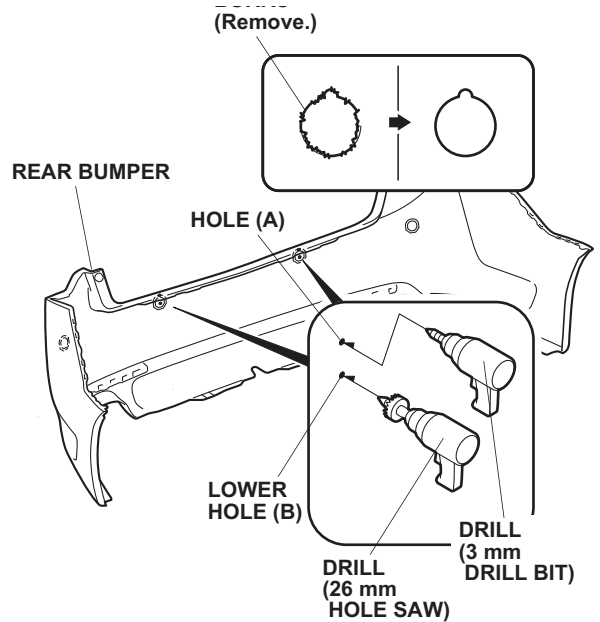

48. Install the two corner sensors on the rear bumper using the two sensor clips as shown.

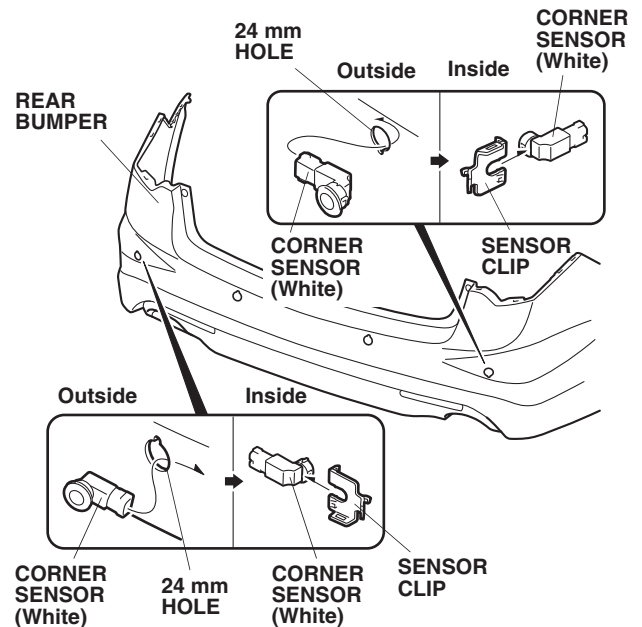

49. Install the two center sensors on the rear bumper using the two sensor clips as shown.

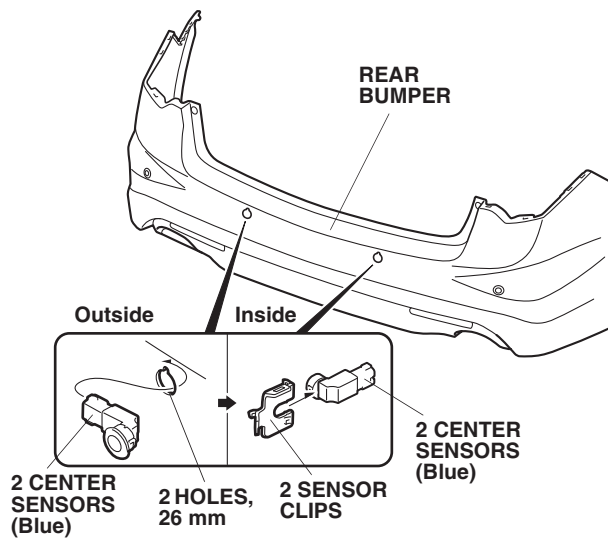

51. Align the two greentapes of the sub harness with the holes on the left center sensor clip and the right center sensor clip, and secure the sub harness to the left center sensor clip and right center sensor clip using two wire ties as shown.

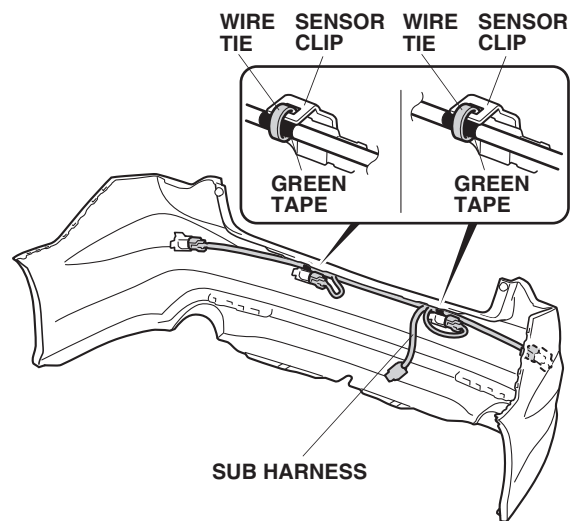

50. Plug in the four sub harness 2-pin connectors to the left center sensor and the right center sensor and the two corner sensors.

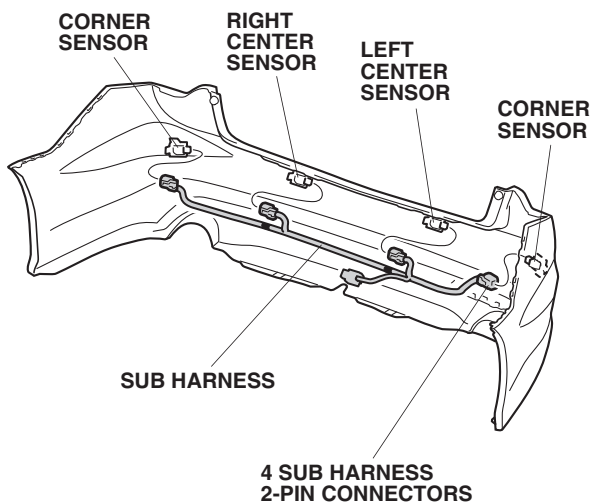

52. Using isopropyl alcohol on a shop towel, clean the area where the harness tape will attach.
53. Attach the sub harness to the rear bumper with three harness tapes.

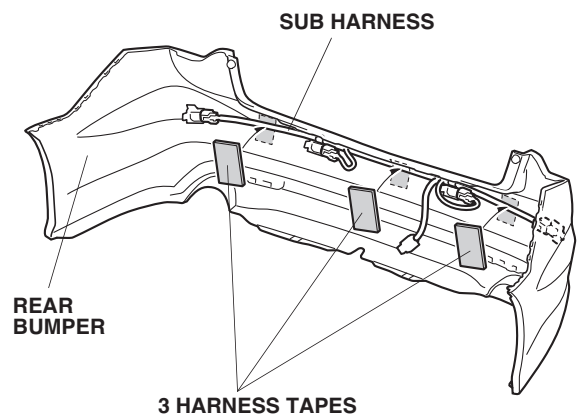

54. With the help of an assistant, bring the rear bumper close to the vehicle. Plug the sub harness 8-pin connector into the sensor harness 8-pin connector, and install the rear bumper in the original position.

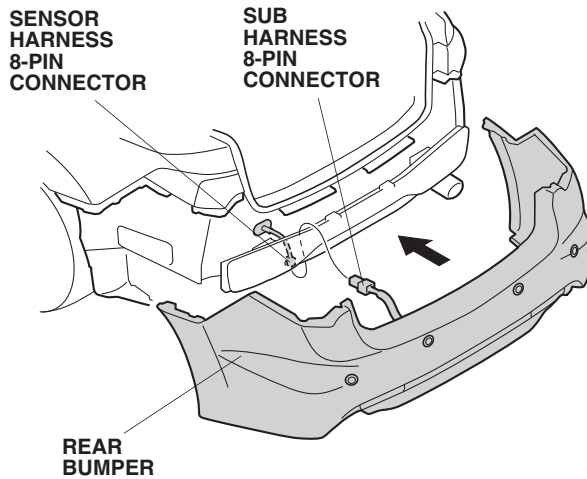

55. Check that all wire harnesses are routed properly and all connectors are plugged in.
56. Reinstall all removed parts.
57. Connect the negative cable to the battery and check operation of all lights and other electrical accessories.
58. Enter the anti-theft codes for the audio system and the navigation system (if equipped).
59. Reset the clock on vehicles without navigation.
60. Check that the back-up sensors work properly as described in the User's information manual supplied with the back-up sensors attachment kit.

Buzzer Volume Control

The original volume setting is turned to maximum volume. The volume level can be adjusted by turning the volume control knob on the control unit using a small flat-tip screwdriver.

