

PARTS LIST

**Backup Sensor Attachment Kit
P/N 08V67-TZ5-200A**

Control unit

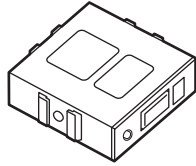

Buzzer



Switch

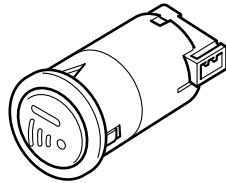

Backup sensor harness

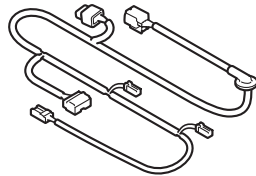

Subharness

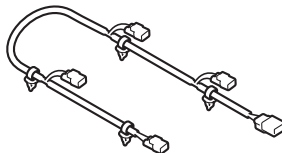

Control unit bracket

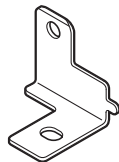

4 Sensor clips

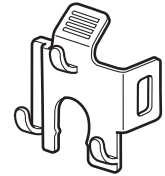

Switch bracket

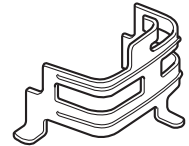

14 Wire ties

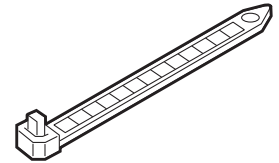

Narrow wire tie

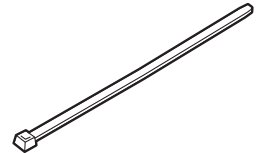

Wire tie with clip

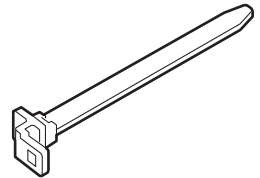

Fuse label



3 Aluminum tapes



2 Urethane tapes

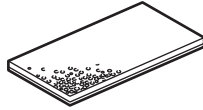

3 Clips



Accessory User's Information Manual

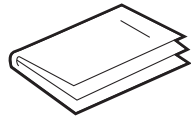

Backup Sensor Kit

NOTE: Refer to Parts Information Bulletin (PIB) for the proper color sensors.

2 Center sensors

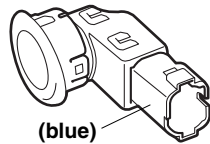

2 Corner sensors

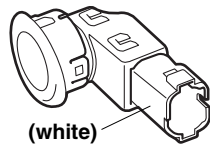

TOOLS AND SUPPLIES REQUIRED

- Phillips screwdriver
- Small flat-tip screwdriver
- 10 mm Open end wrench
- Ratchet
- Torque wrench
- 10 mm and 14 mm Sockets
- Pushpin
- Drill
- 3 mm Drill bit
- 24 mm and 26 mm Hole saws
- File
- Ruler
- Felt-tip pen
- Scissors
- Tape
- Utility knife
- Diagonal cutters
- Isopropyl alcohol
- Shop towel
- Rubber mallet
- Blanket
- Eye protection (face shield, safety goggles, etc.)

The following tools are available through the Honda Tool and Equipment Program. On the iN, click on: Service > Service Bay > Tool and Equipment Program, then enter the number under "Search". Or, call 888-424-6857.

- Trim Tool Set (T/N SOJATP2014)
- Plastic Trim Tool (T/N SILTRIMTL10)

Illustration of the Backup Sensors Installed on the Vehicle

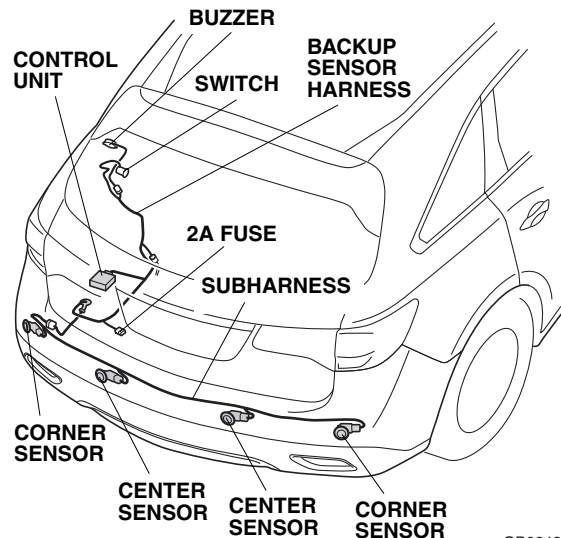

QB02436BH

INSTALLATION

Client Information: The information in this installation instruction is intended for use only by skilled technicians who have the proper tools, equipment, and training to correctly and safely add equipment to your vehicle. These procedures should not be attempted by “do-it-yourselfers.”

NOTE: Refer to Parts Information Bulletin (PIB) for the proper color sensors.

Removing the Vehicle Parts

1. Disconnect the negative cable:
 - Wrap a shop towel around the hood latch.

HOOD LATCH
(Wrap with
a shop towel.)

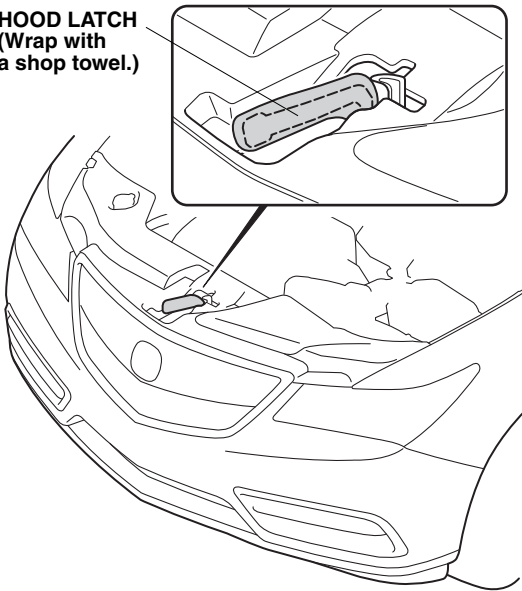

QBN1201BK

- Remove the front bulkhead cover (10 clips).

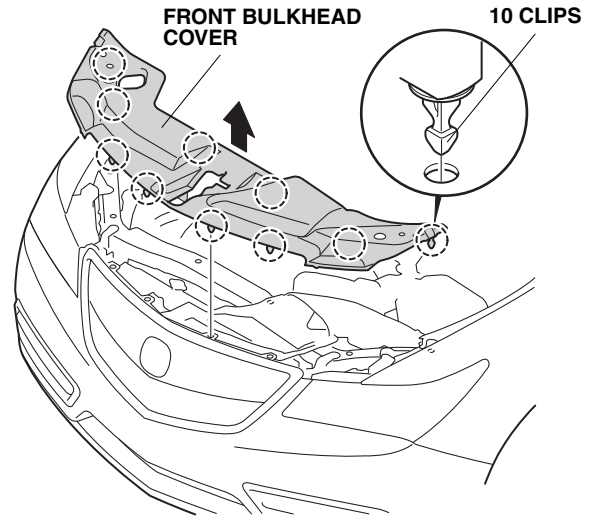

QBN1202BK

- Remove the intake air tube (two clips).
- Disconnect the negative cable from the battery.

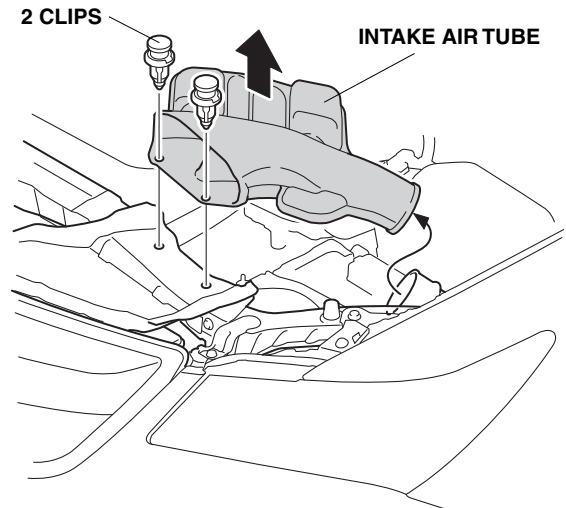

QBN1504BK

2. Pull each lever, and fold down the left and right third row seats.

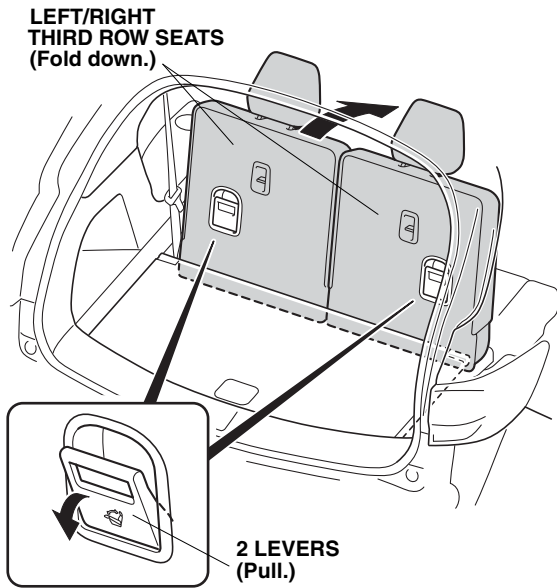

QB01910AH

3. Using a plastic trim tool, open the four tie down hook caps. Remove four tie down hooks (one screw for each hook).

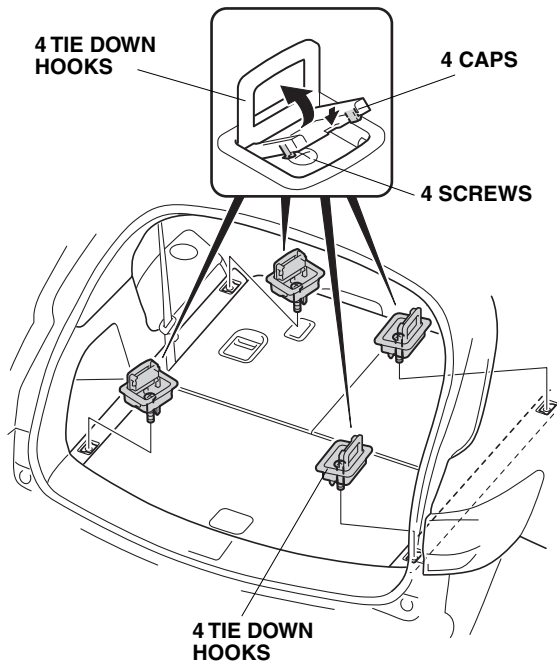

QB02437AH

4. Remove the left and right load floor strips (1 clip and 14 retaining tabs for each trim).

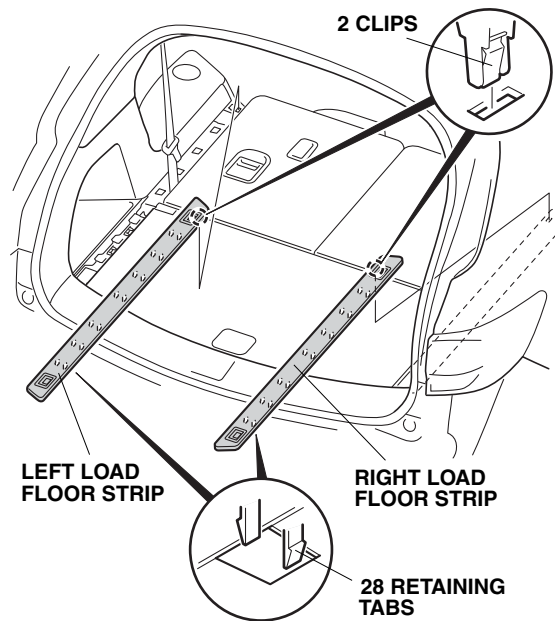

QB01911AH

5. Remove the cargo lid (two bolts).

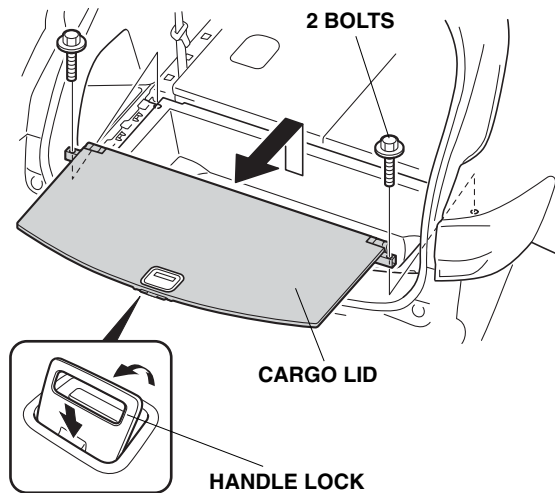

QB01912AH

6. Remove the cargo lining.

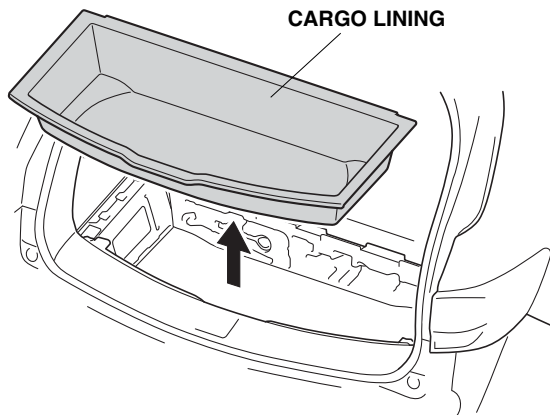

QB01913AH

7. Remove the tool set box.

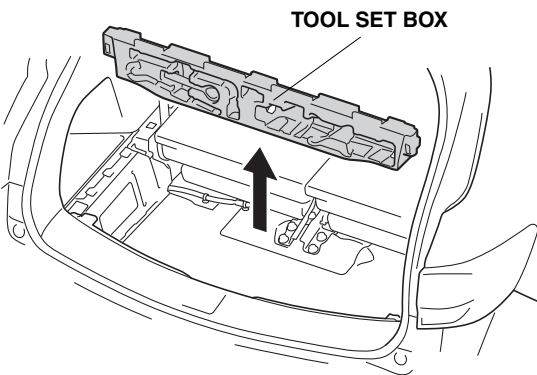

QB01914AH

8. Remove the rear trim panel (one bolt, four clips, and four retaining tabs).

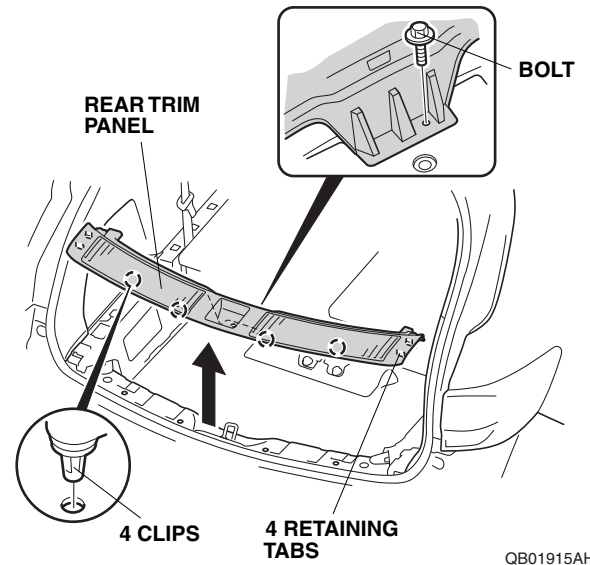

QB01915AH

9. Raise the left and right third row seats. Remove two bolts from the left third row seat.

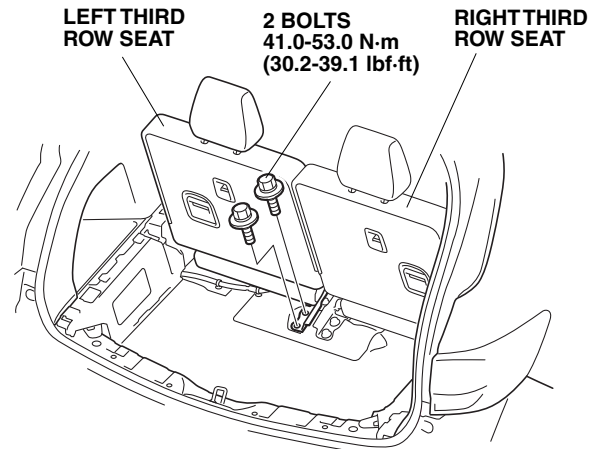

QB01916AH

- Remove the two seat track end covers (two retaining tabs for each cover).

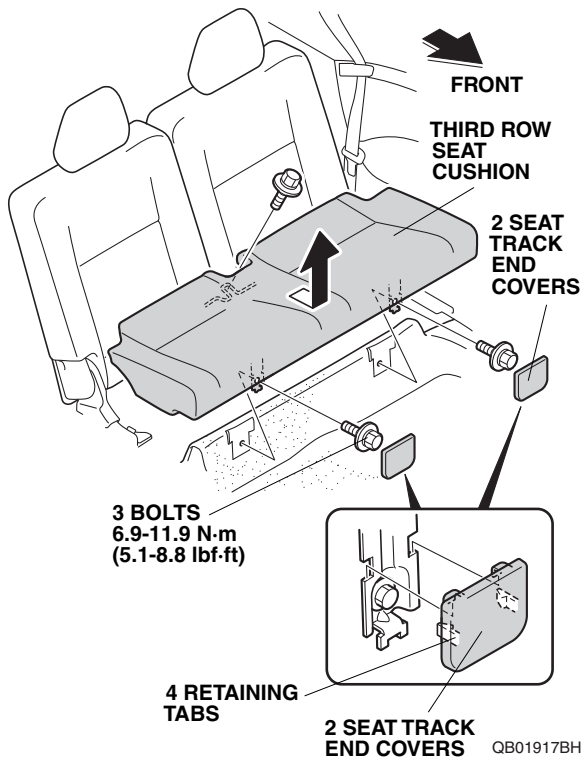

- Remove the third row seat cushion (three bolts).
- Remove the left third row seat-back (two bolts and one hook).

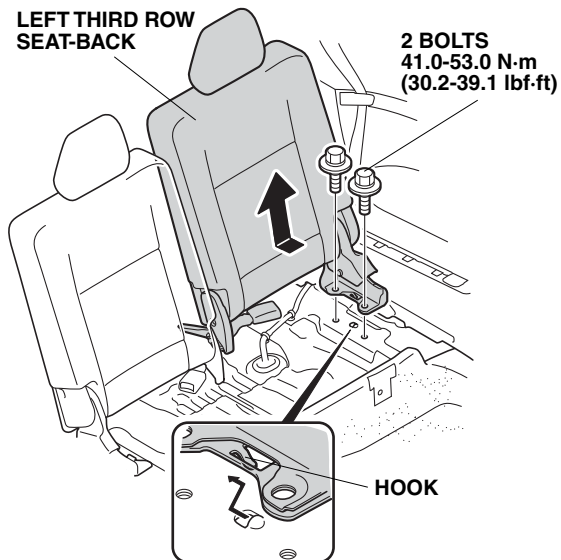

QB01918AH

- Release the three clips and three retaining tabs, then lift the left rear side upper garnish.

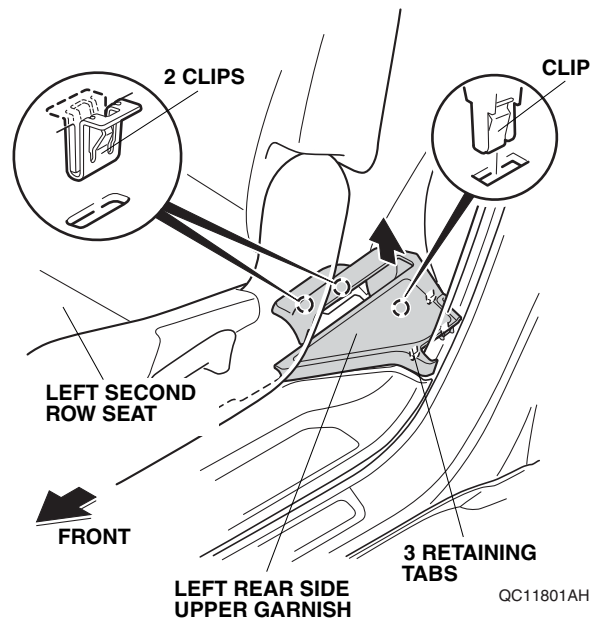

14. Pull away the weatherstrip and the door opening seal. Remove the left rear side trim panel (seven clips, nine retaining tabs, lift the left rear side upper garnish, and unplug the vehicle connector).

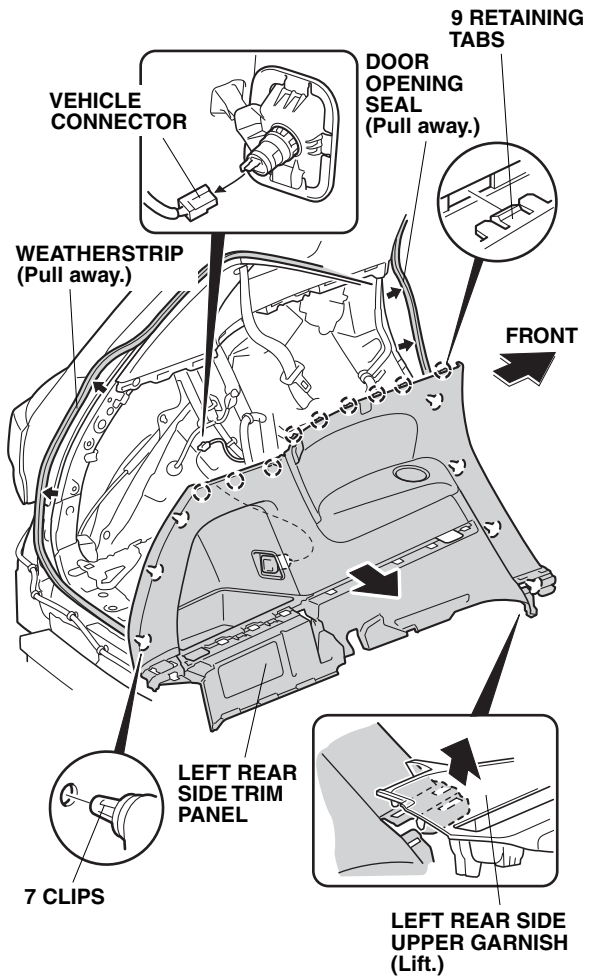

QB01919CH

15. Pull away the weatherstrip. Remove the rear roof garnish (five clips, six retaining tabs, and two hooks).

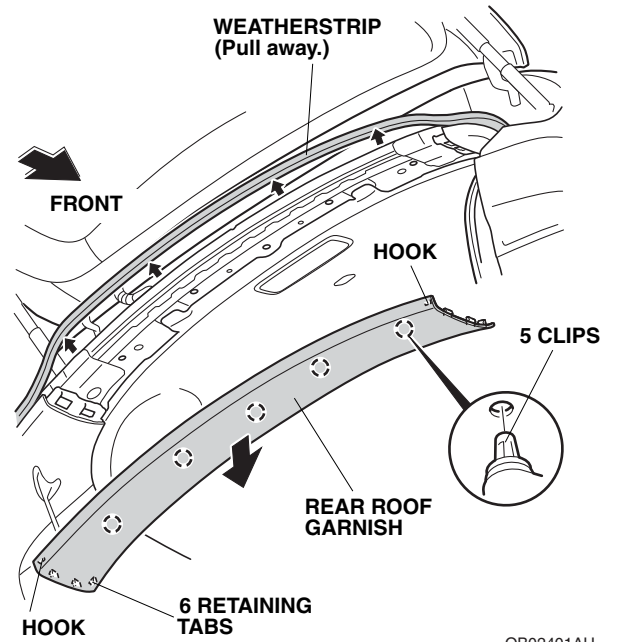

QB02401AH

16. Pull away the weatherstrip and the door opening seal. Using a rubber mallet and a shop towel, gently tap the left quarter pillar trim at the positions shown to release three clips. Make sure to strike area perpendicularly to the vehicle.

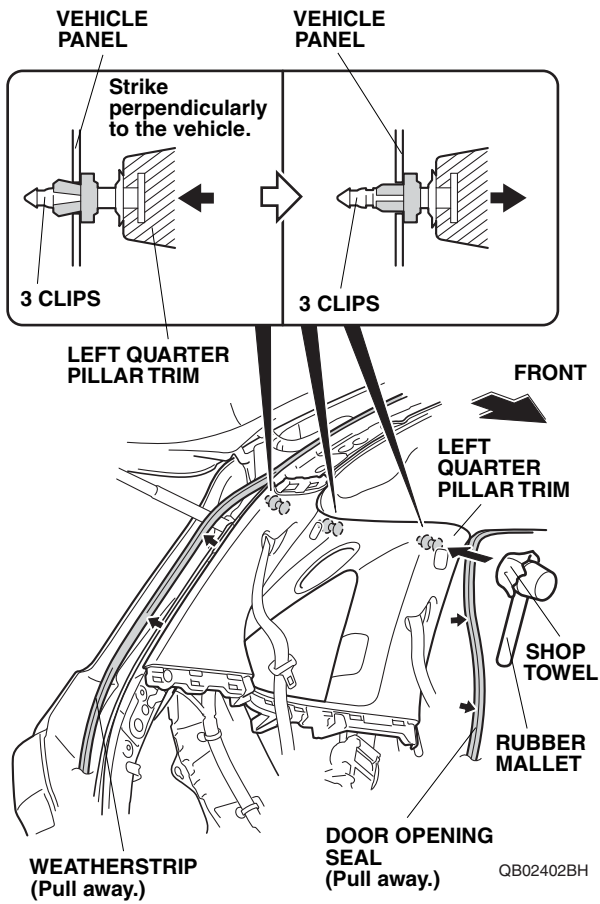

17. Remove the left quarter pillar trim (seven clips, and unplug the vehicle connector, if equipped).

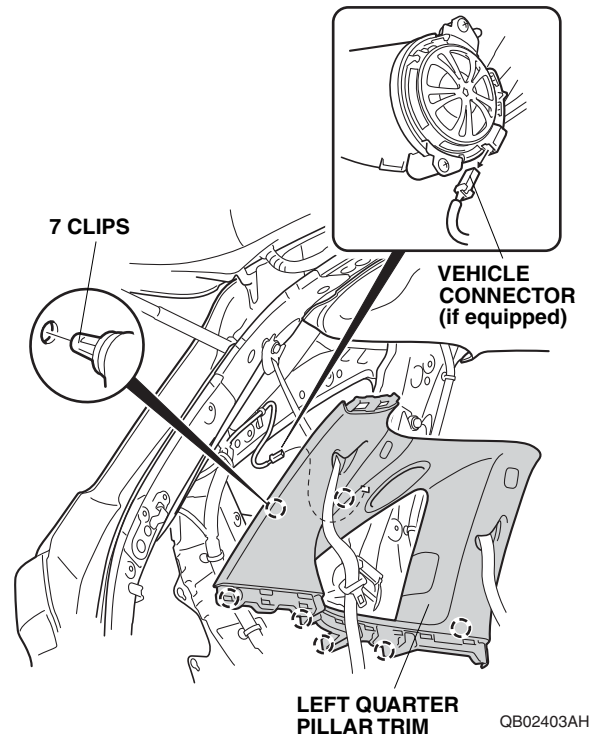

18. Remove the rear bumper:
- Attach tape to the areas as shown on each side.

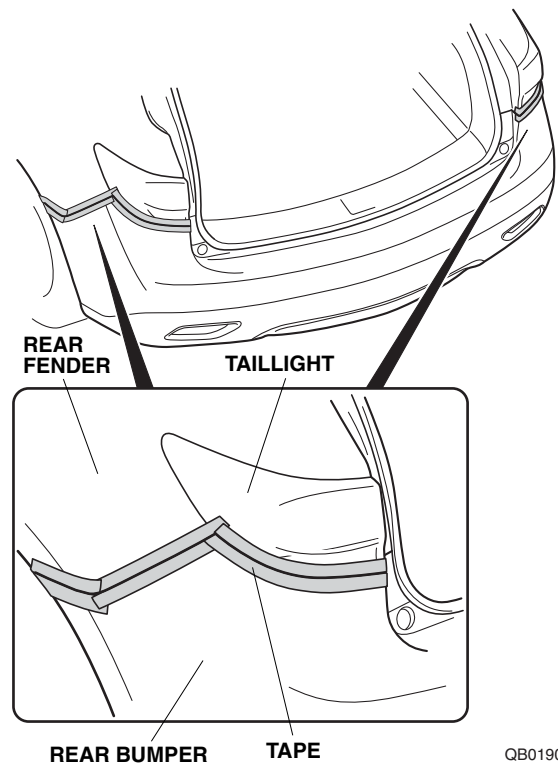

- Pull away the weatherstrip.

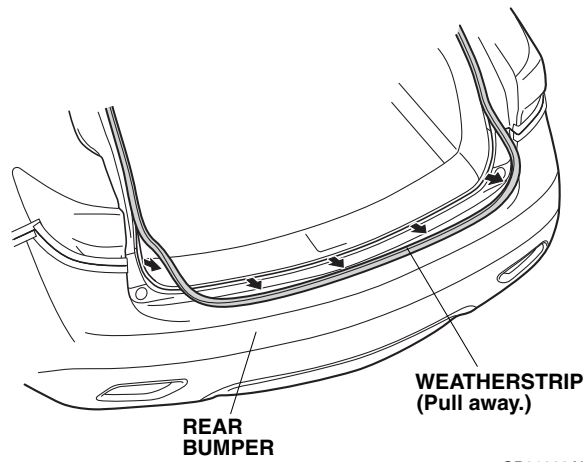

QB01902AH

- Using a plastic trim tool, remove two plug caps (four retaining tabs for each plug cap).

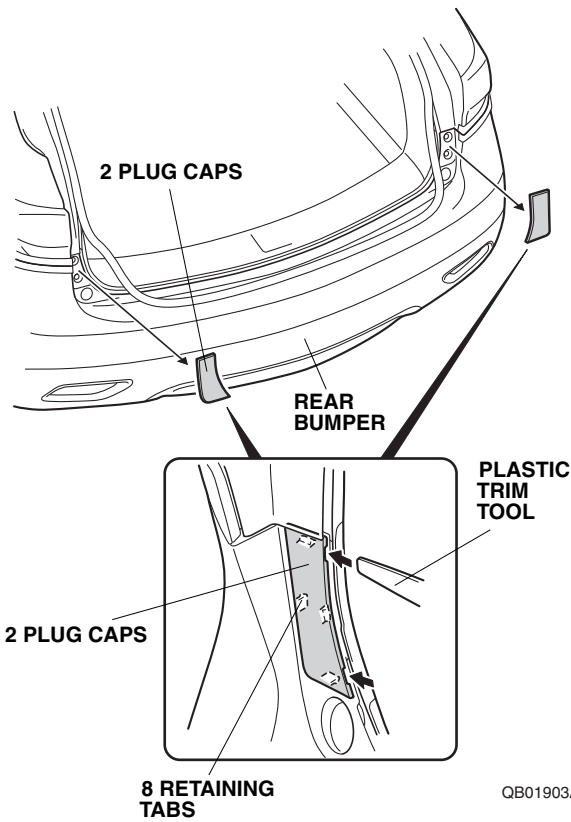

QB01903AH

- Remove four bolts and two clips.

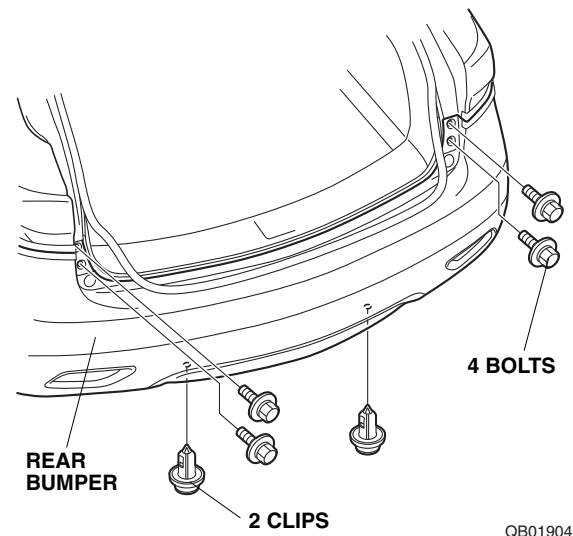

QB01904AH

- Remove five self-tapping screws on each side.

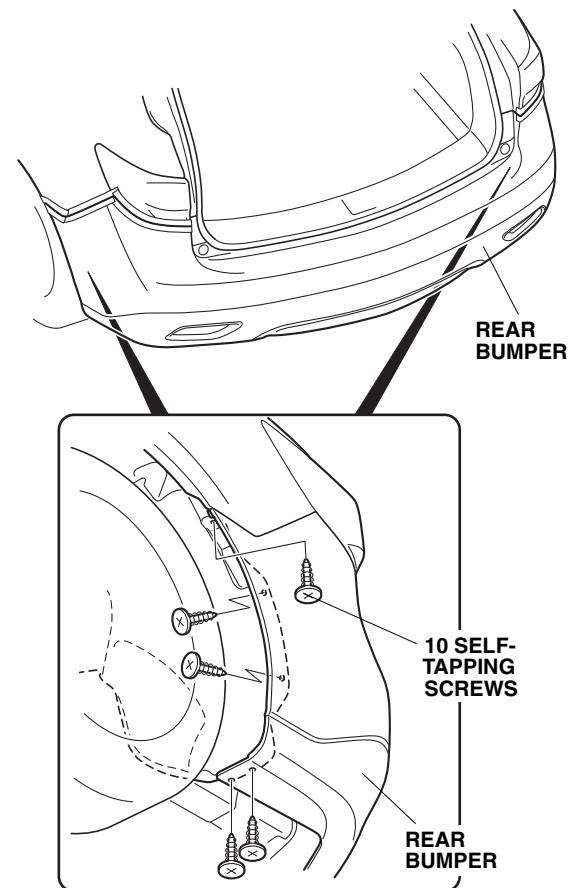

QB01905AH

- Release eight retaining tabs on each side.

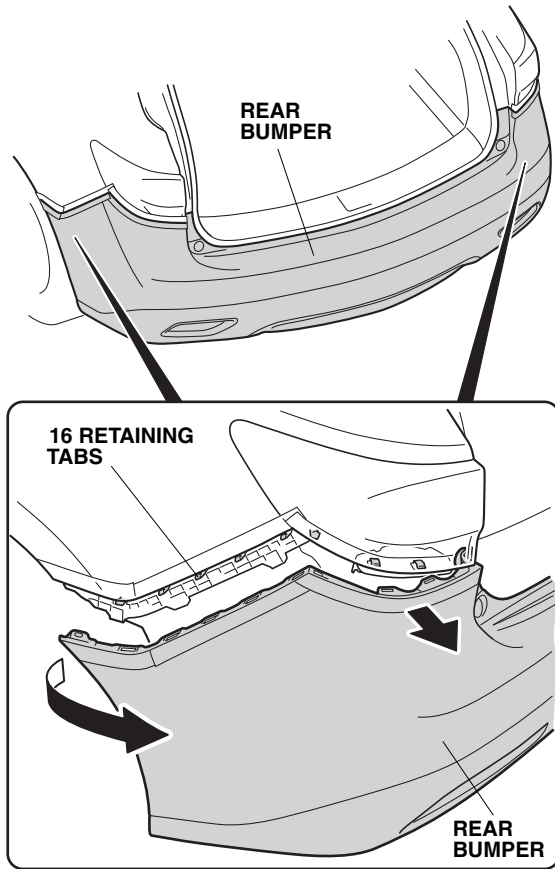

QB01906AH

- With the help of an assistant, remove the rear bumper (four retaining tabs). Place the rear bumper on a blanket to prevent damage.

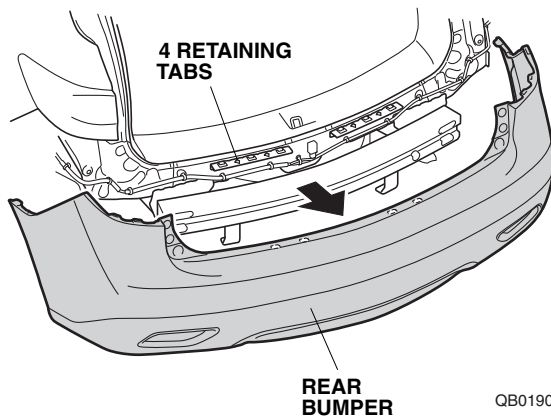

QB01907AH

Installing the Control Unit

- Get the backup sensor harness. Using isopropyl alcohol on a shop towel, thoroughly clean the backup sensor harness fuse case where the fuse label will attach.

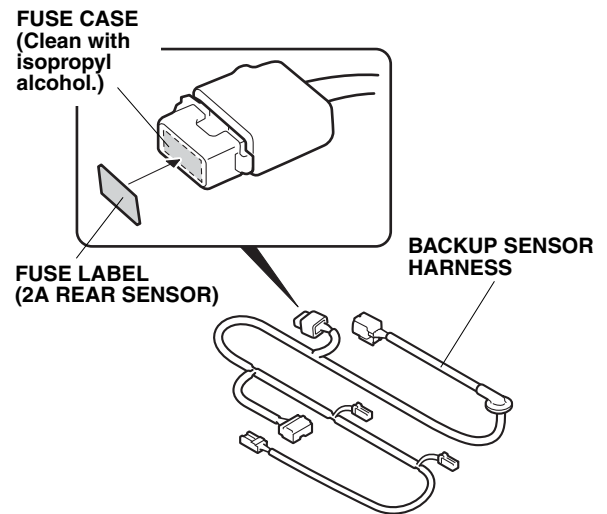

QC11802AH

- Attach the fuse label (2A REAR SENSOR) to the backup sensor harness fuse case.
- Using isopropyl alcohol on a shop towel, thoroughly clean the control unit where the urethane tape will attach.

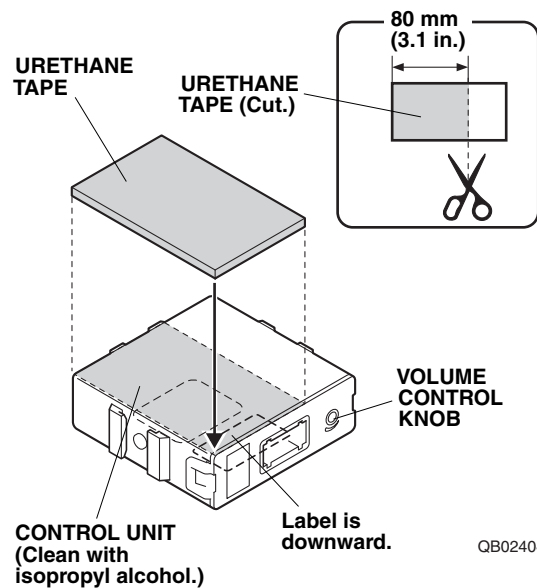

QB02404AH

- Using scissors, cut one urethane tape to the measurement shown. Attach the cut urethane tape to the control unit as shown.

23. Install the control unit bracket to the control unit.

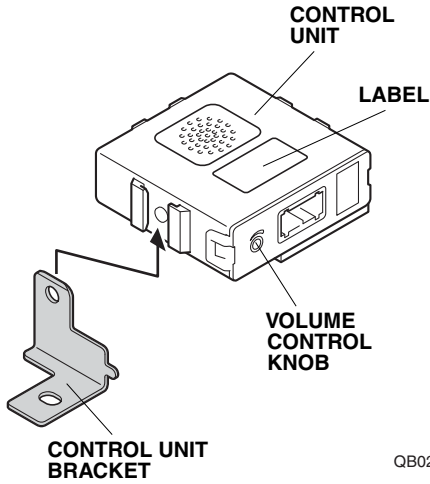

24. Remove one vehicle bolt from the vehicle bracket. Install the control unit to the vehicle bracket using the vehicle bolt.

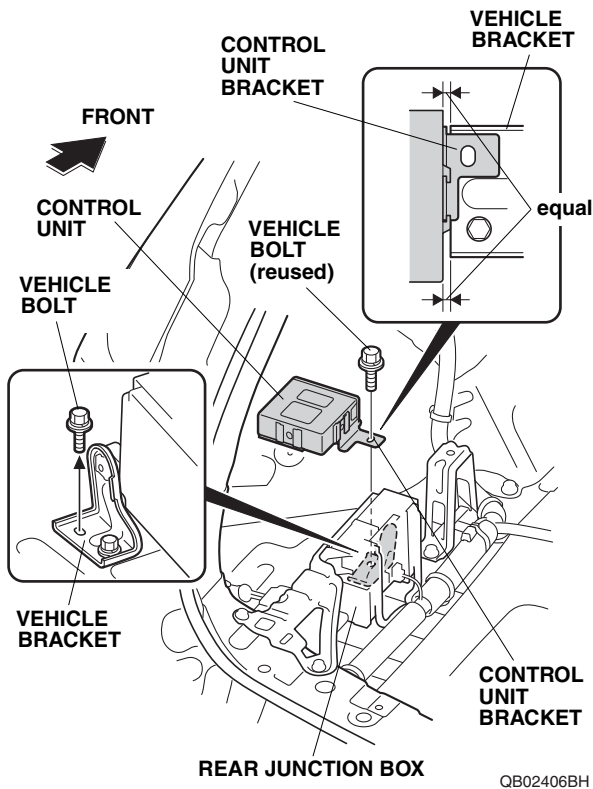

25. Loosen two vehicle bolts on the bracket of the fuel fill door release actuator, slide off of the bracket, and move out of the way.

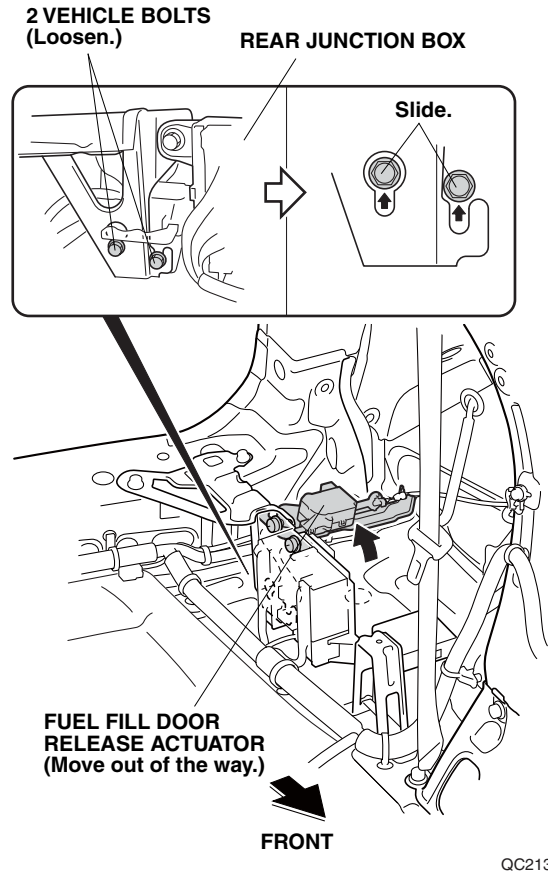

26. Locate and remove the vehicle grommet from the floor panel.

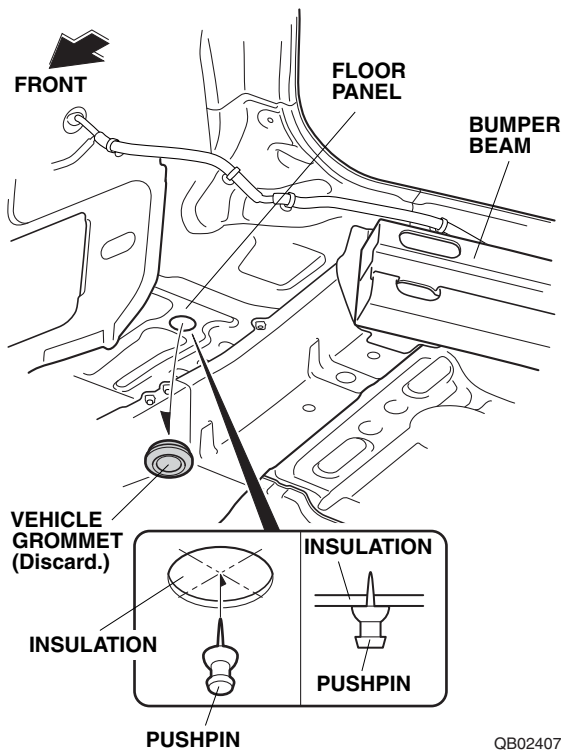

27. Using a pushpin, pierce the insulation.
28. Using a utility knife, cut the insulation at the area shown. Do not damage the floor panel.

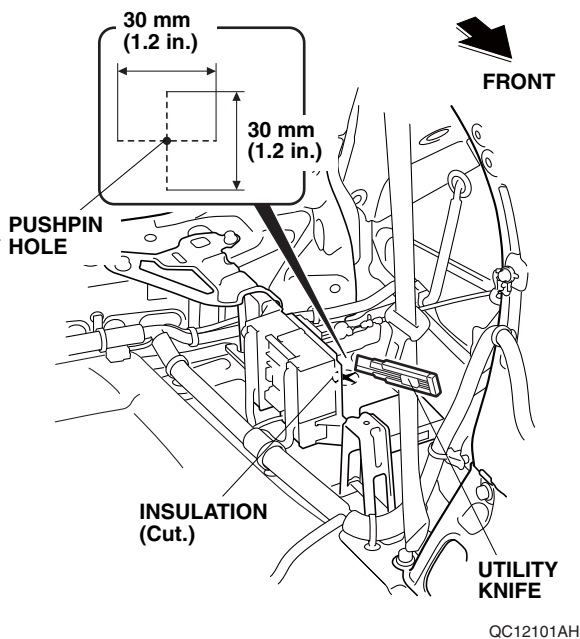

29. Route the backup sensor harness 8-pin connector through the vehicle grommet hole, and seat the backup sensor harness grommet into the vehicle grommet hole.

NOTE:

- Install the backup sensor harness by holding the grommet.
- Make sure to check that the grommet is secured properly.

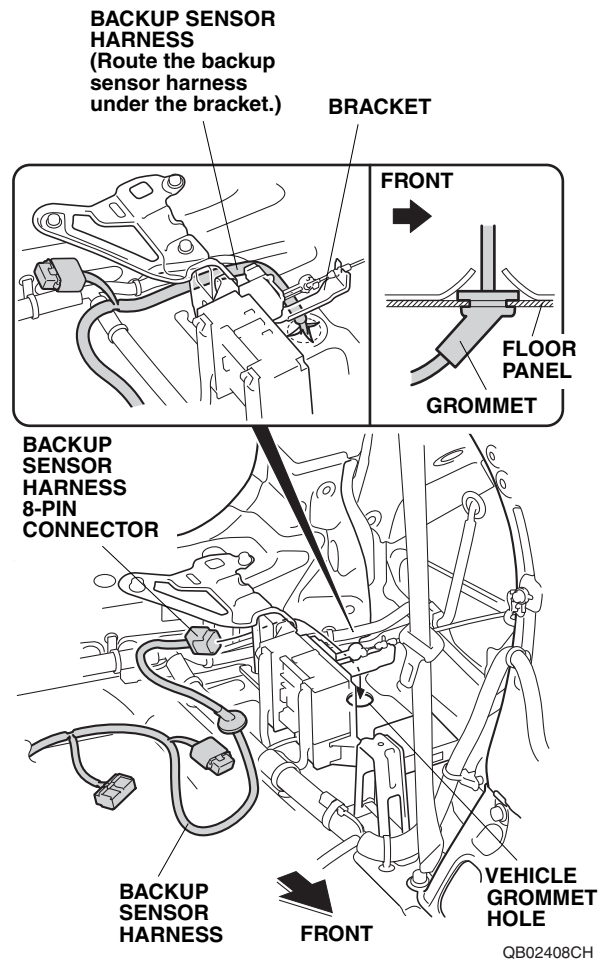

30. Reinstall the fuel fill door release actuator.

31. Secure the backup sensor harness 8-pin connector to the vehicle harness with one wire tie with clip.

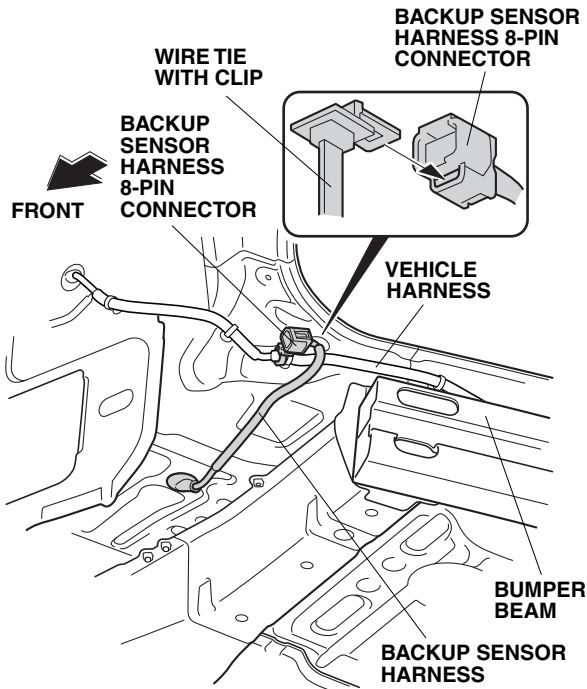

QB02409BH

32. Route the backup sensor harness along the vehicle harness, and secure the backup sensor harness to the vehicle harness with four wire ties.

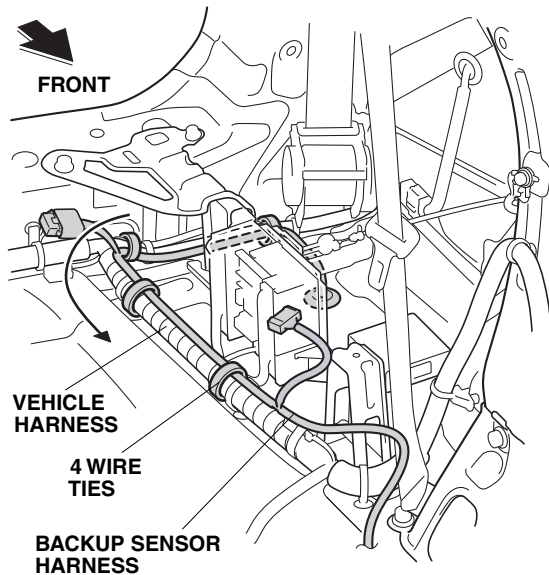

QB02410BH

33. Secure the backup sensor harness fuse case to the vehicle harness with one wire tie.

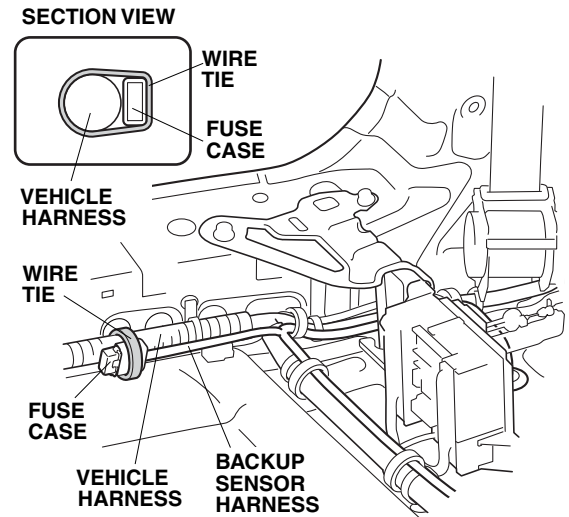

WITH TRAILER HITCH HARNESS

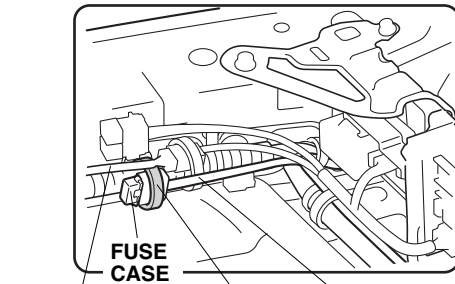

Do not clamp the trailer hitch harness.

BACKUP SENSOR HARNESS

QC12102AH

34. Plug the backup sensor harness 14-pin connector into the control unit.

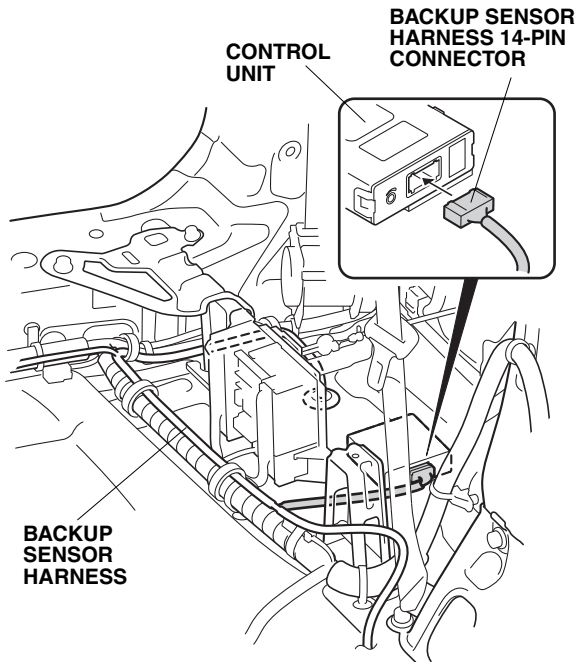

QB02411BH

35. Locate and remove the blue tape from the vehicle harness to free the vehicle 2-pin connector.

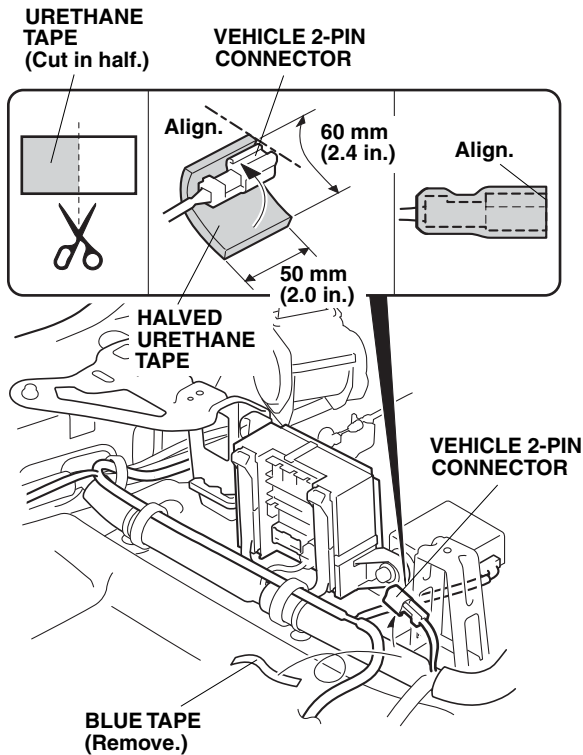

QB02412CH

36. Using scissors, cut one urethane tape in half. Wrap one half of the urethane tape around the vehicle 2-pin connector as shown.

37. Plug the backup sensor harness 2-pin connector into the vehicle 2-pin connector.

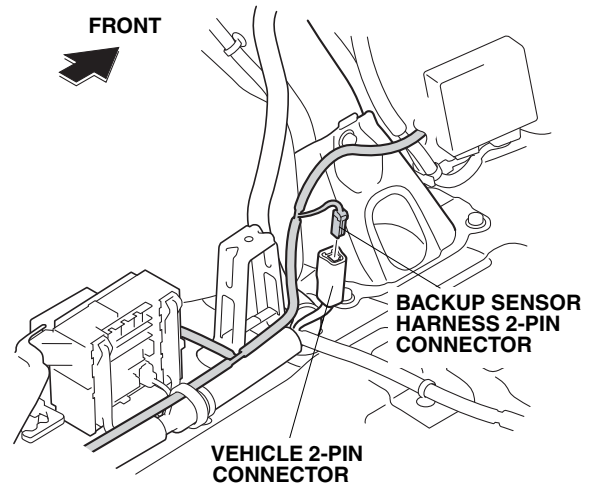

QB02413BH

38. Secure the backup sensor harness to the vehicle harness with five wire ties.

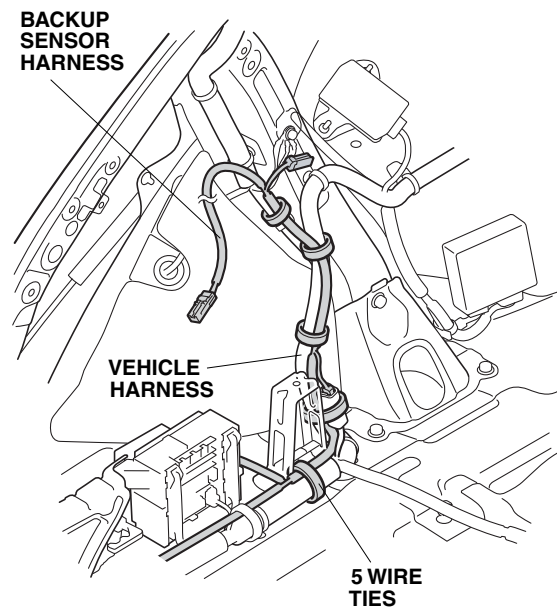

QB02414CH

Installing the Buzzer

39. Get the buzzer. Wrap the remaining half of urethane tape (from step 36.) around the buzzer 2-pin connector as shown.

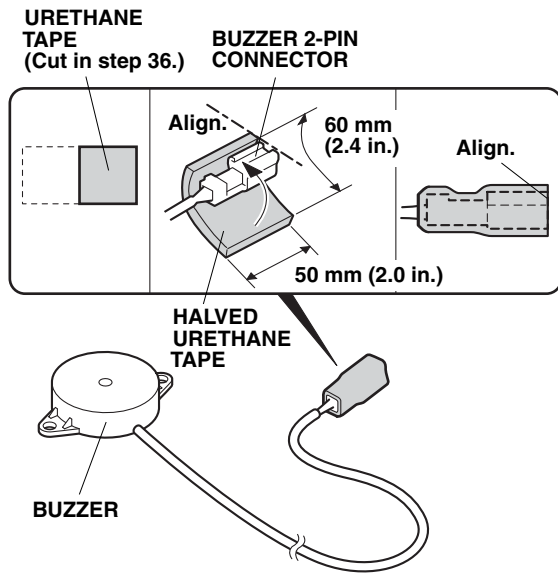

QB02415BH

40. Using isopropyl alcohol on a shop towel, thoroughly clean the vehicle panel where the buzzer will attach.

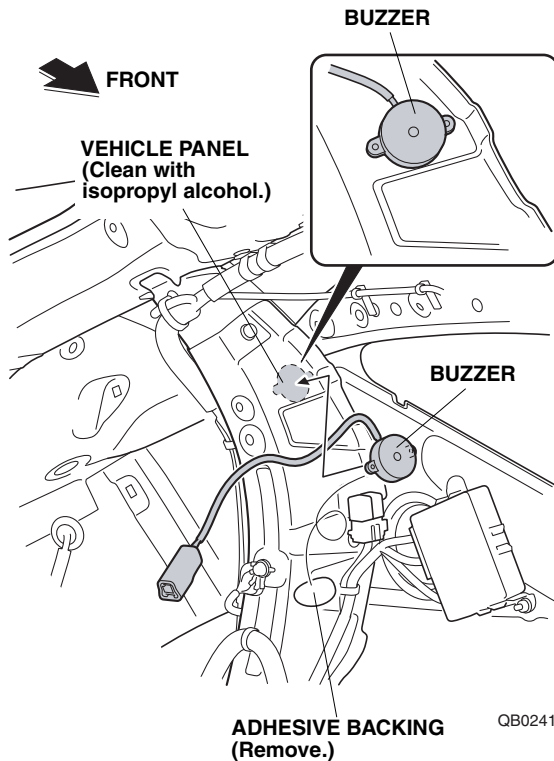

QB02416AH

41. Remove the adhesive backing from the buzzer, and attach the buzzer to the vehicle panel in the location shown.

42. Plug the backup sensor harness 2-pin connector into the buzzer 2-pin connector.

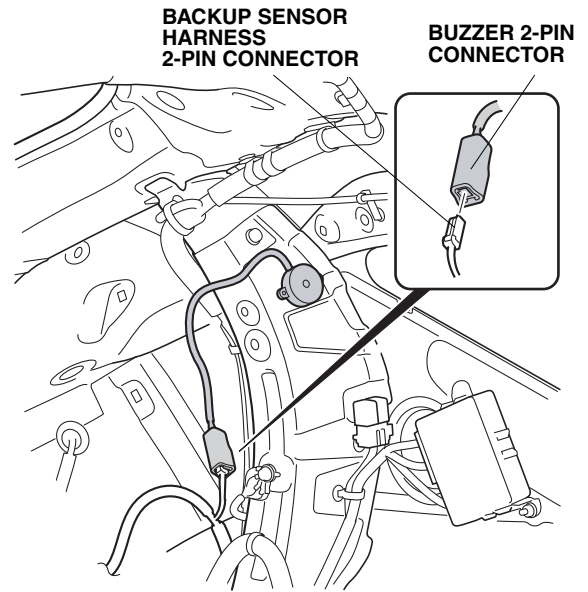

QB02417AH

43. Secure the buzzer 2-pin connector and backup sensor harness to the vehicle harness with one wire tie.

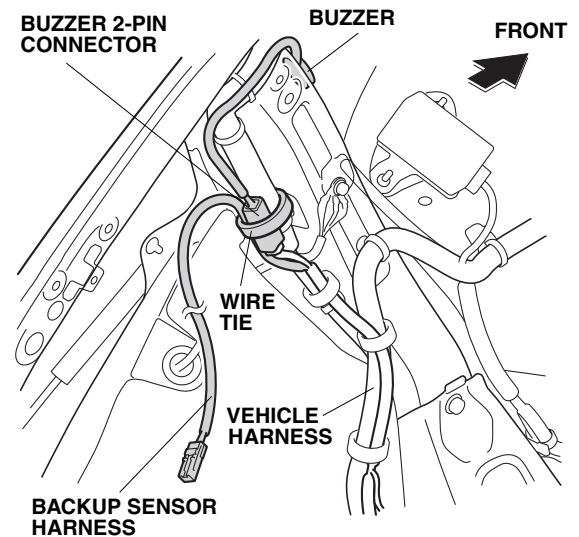

QB02418BH

44. Secure the buzzer harness and backup sensor harness to the vehicle harness with three additional wire ties as shown.

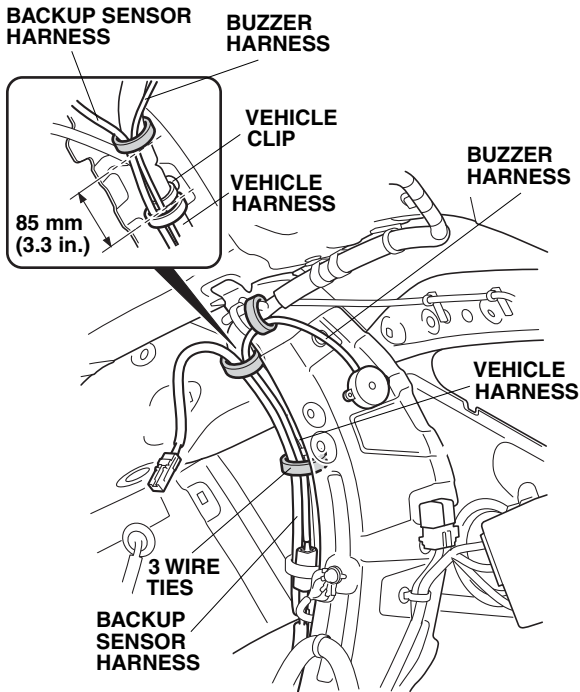

QB02419AH

Installing the Switch

45. Using a ruler and a felt-tip pen, measure and mark the left quarter pillar trim at the measurement shown.

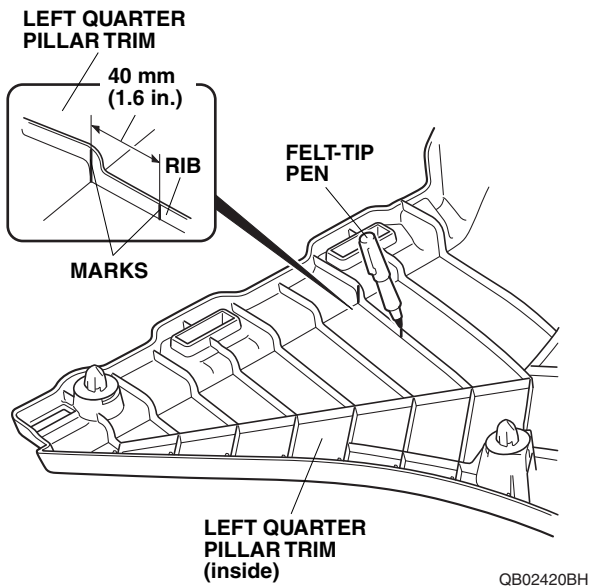

QB02420BH

46. Using a utility knife, cut out the rib on the left quarter pillar trim. Remove any burrs.

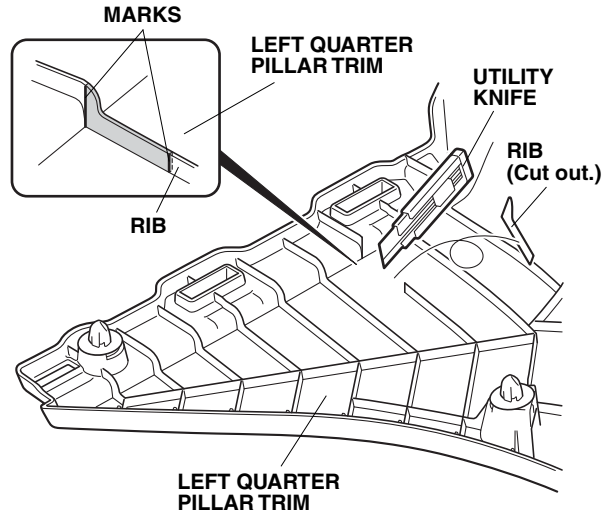

QB02421BH

47. Using a pushpin, pierce the left quarter pillar trim at the measurements shown.

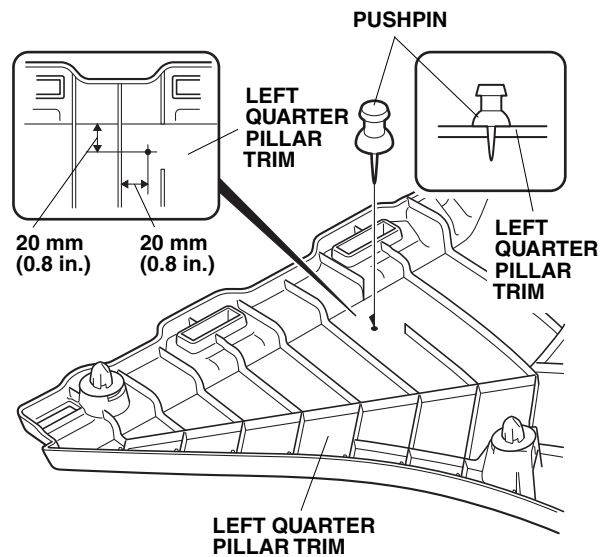

QB02422BH

48. While wearing eye protection, drill the pierced mark on the left quarter pillar trim with a 3 mm drill bit. Enlarge the 3 mm hole to 26 mm using a 26 mm hole saw. Remove any burrs.

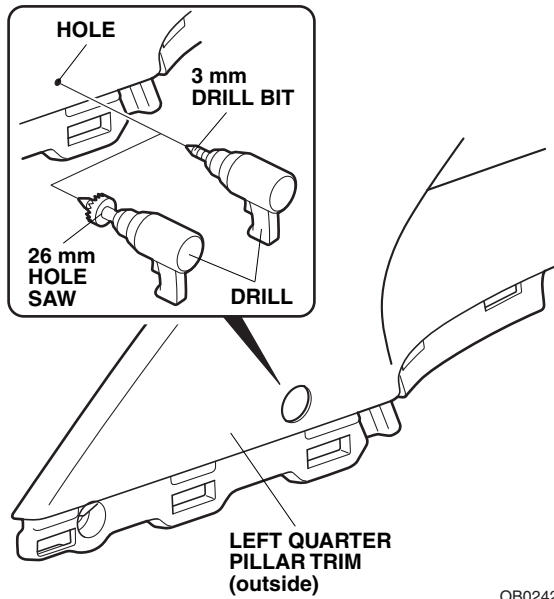

QB02423AH

49. Install the switch into the 26 mm hole in the left quarter pillar trim. Make sure the switch is installed in the direction shown.

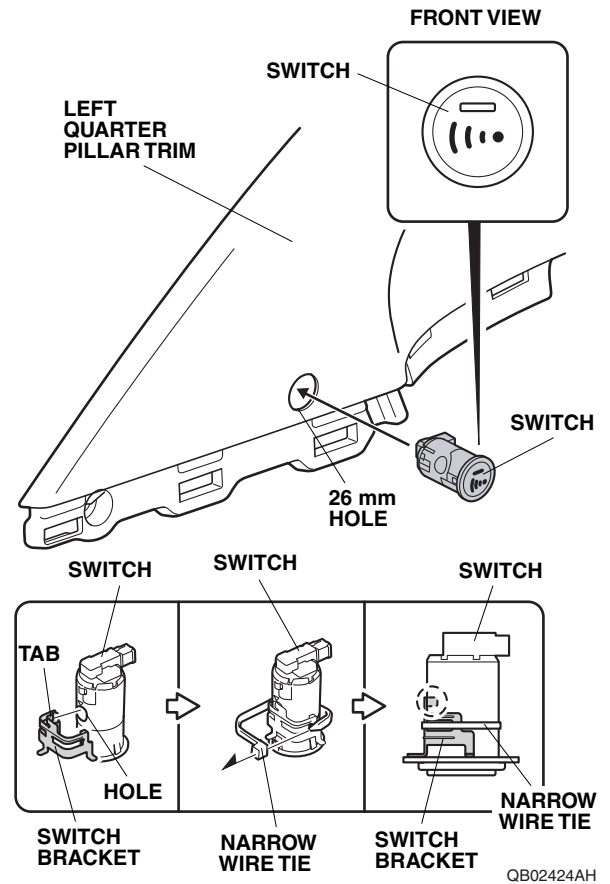

50. Align the tab on the switch bracket with the hole in the switch, and secure the switch bracket to the switch with one narrow wire tie. Firmly press the switch bracket against the left quarter pillar trim, and make sure that there is no clearance between the switch and left quarter pillar trim.

51. On the inside of the left quarter pillar trim, remove and discard three vehicle clips, and install three new clips (supplied) to the left quarter pillar trim.

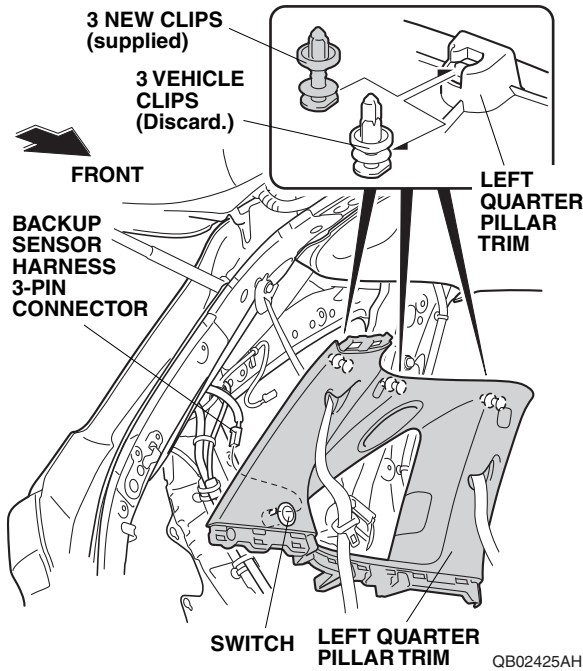

52. Check the overlap between the headliner and the left quarter pillar trim. Refer to the Service Manual. If necessary, adjust the overlap.
53. Bring the left quarter pillar trim into position. Plug the backup sensor harness 3-pin connector into the switch, and reinstall the left quarter pillar trim. NOTE: Make sure the side curtain airbag is not tucked under the clips. Do not push the quarter pillar trim excessively.

Installing the Backup Sensors

54. Mark the inside of the rear bumper:
- Locate the four scribe marks on the inside of the rear bumper at the center and on each side.
 - Using a pushpin, pierce the rear bumper at the top and center of the four scribe marks. NOTE: Make sure to pierce the scribe marks perpendicularly to the rear bumper.

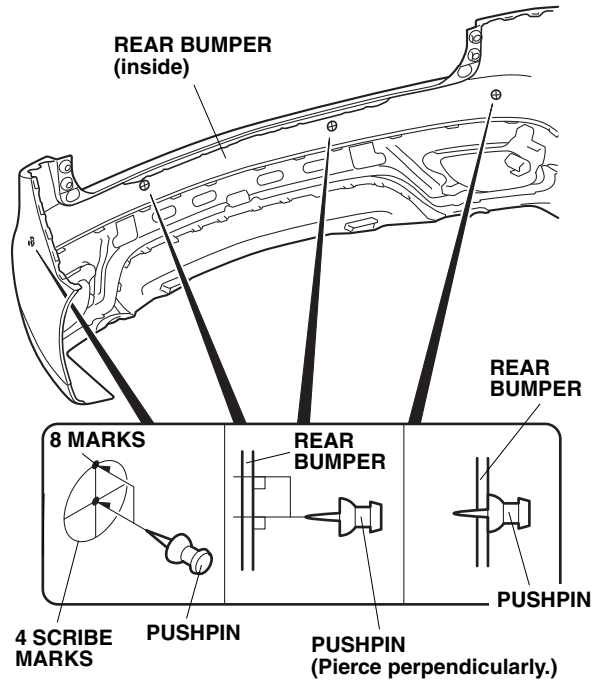

QB02426AH

55. While wearing eye protection, drill the eight pierced marks with a 3 mm drill bit from outside of the rear bumper.
- NOTE: Make sure to drill perpendicularly to the rear bumper.

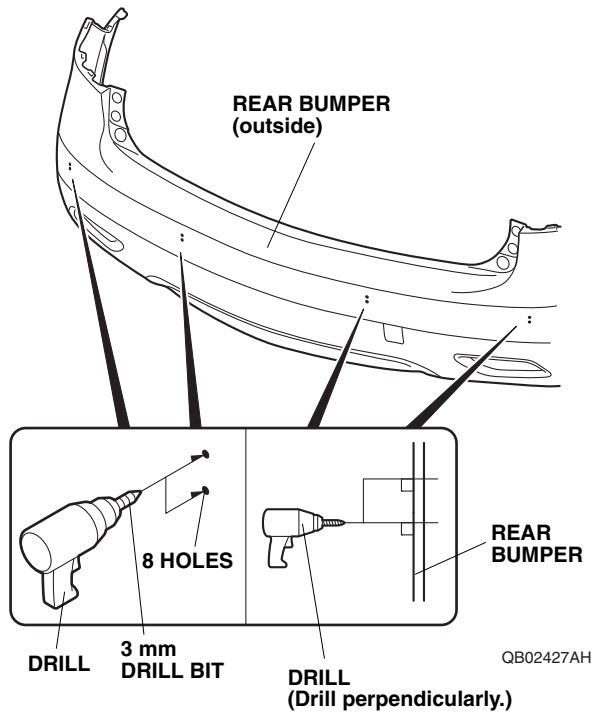

56. While wearing eye protection, and drilling from outside of the rear bumper, enlarge the two lower 3 mm outer holes to 24 mm using a 24 mm hole saw.
- NOTE: Make sure to drill perpendicularly to the rear bumper. Remove any burrs.

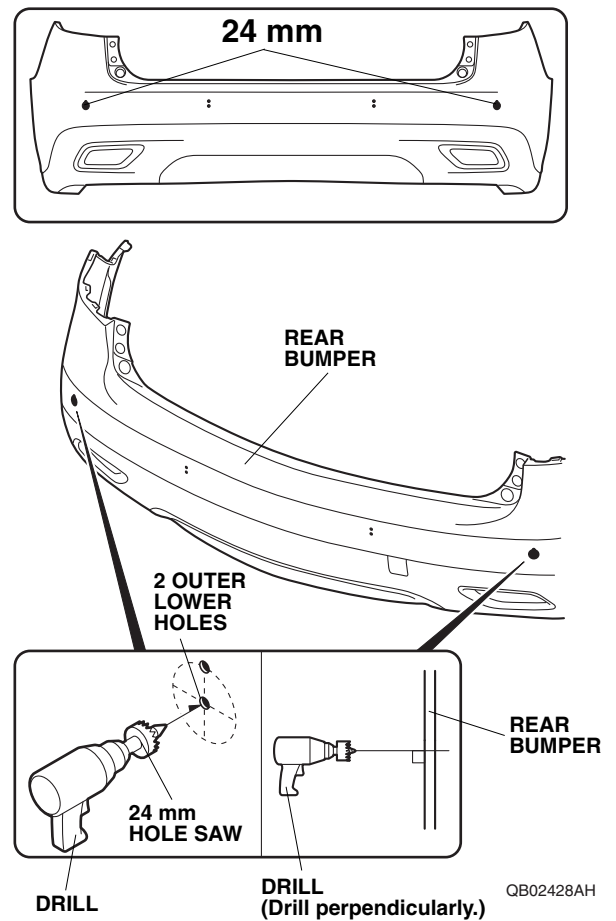

57. While wearing eye protection, and drilling from outside of the rear bumper, enlarge the two lower 3 mm inner holes to 26 mm using a 26 mm hole saw. NOTE: Make sure to drill perpendicularly to the rear bumper. Remove any burrs.

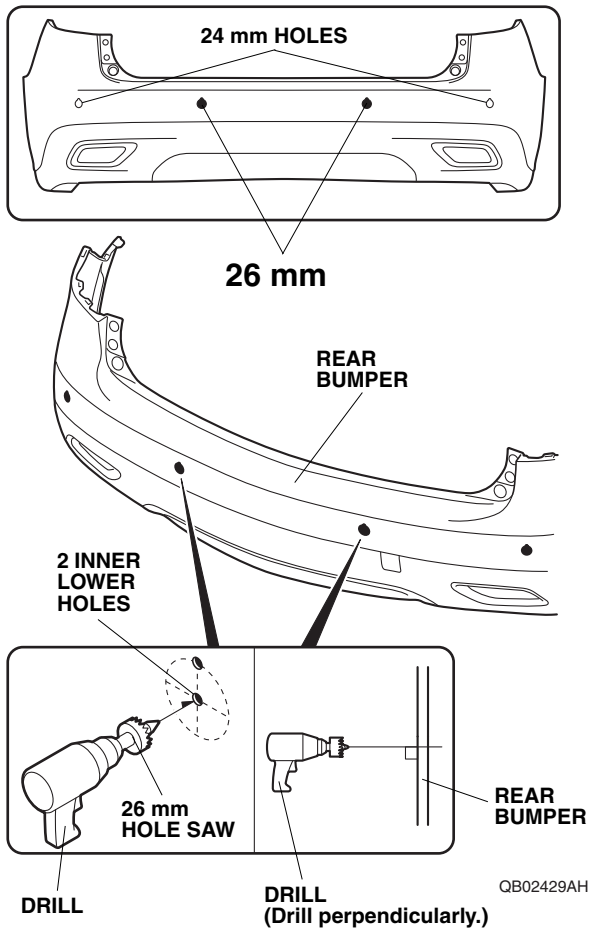

58. Insert the two corner sensors (white) to the rear bumper, and secure them with the two sensor clips as shown.

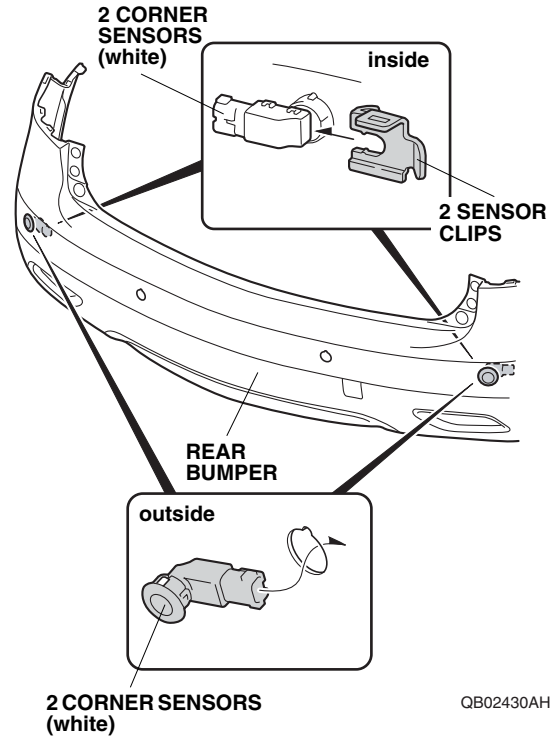

59. Insert the two center sensors (blue) to the rear bumper, and secure them with the two sensor clips as shown.

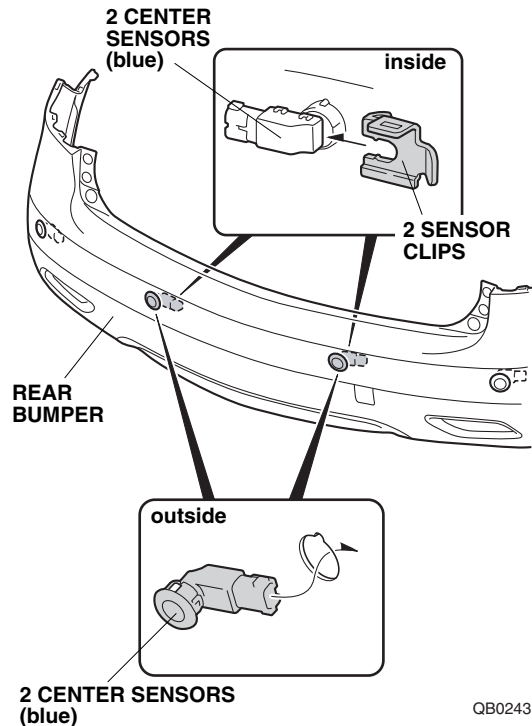

60. Plug the four subharness 2-pin connectors into the two center sensors (blue) and the two corner sensors (white).

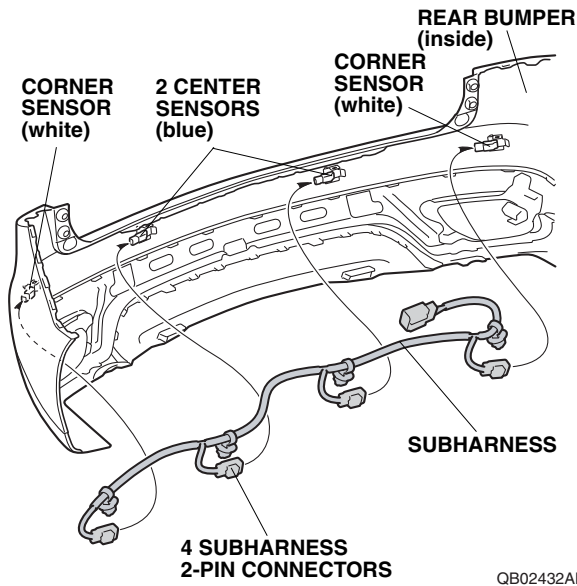

61. Secure the four subharness clips to the four sensor clips.

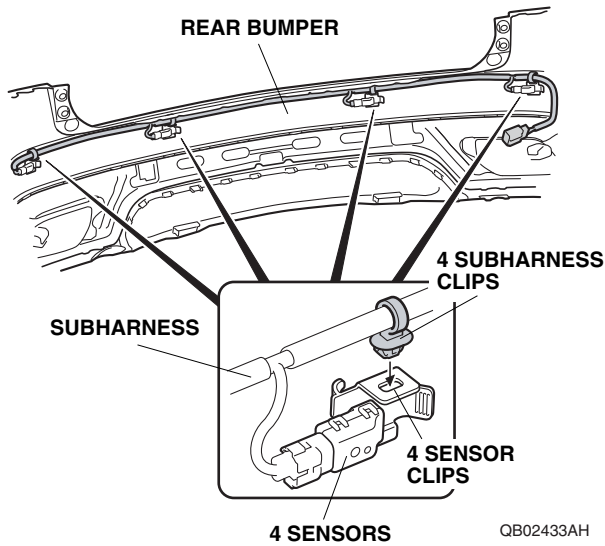

62. Using isopropyl alcohol on a shop towel, thoroughly clean the rear bumper where the aluminum tapes will attach.

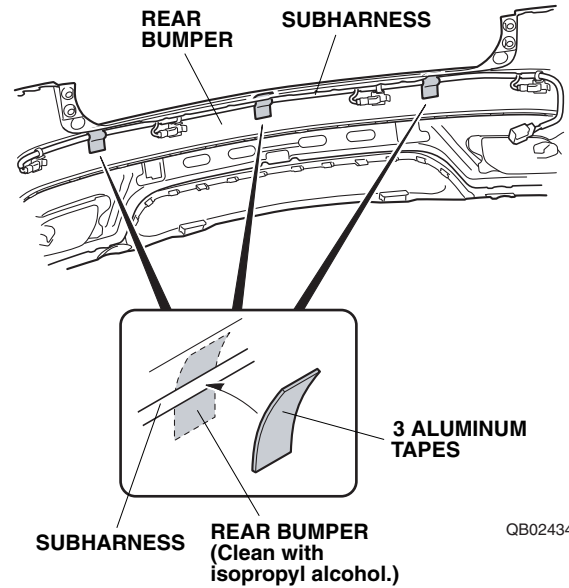

63. Secure the subharness to the rear bumper with the three aluminum tapes at the areas shown.

64. With the help of an assistant, bring the rear bumper to the vehicle, and plug the subharness 8-pin connector into the backup sensor harness 8-pin connector. Reinstall the rear bumper.

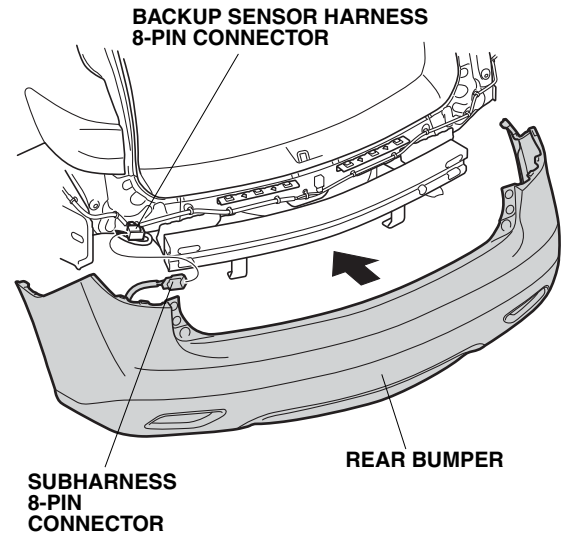

65. Check that all wire harnesses are routed properly and that all connectors are plugged in.
66. Reinstall all removed parts except for the front bulkhead cover and the intake air tube.
67. Reconnect the negative cable to the battery.
68. Reinstall the front bulkhead cover and the intake air tube.
69. Press and hold the radio power button for two seconds to restore the radio and navi (if equipped) system functions.
70. Reset the clock on vehicles without navigation.
71. Check that the backup sensors work properly as described in the Accessory User's Information Manual supplied with the backup sensor attachment kit.
72. Restore the systems back to normal operation as described in the Service Manual if necessary.

BUZZER VOLUME CONTROL

After operation check, adjust the volume if necessary. The volume level can be adjusted by turning the volume control knob on the control unit using a small flat-tip screwdriver.

NOTE: Make sure not to excessively turn to adjust or it may damage the control unit.

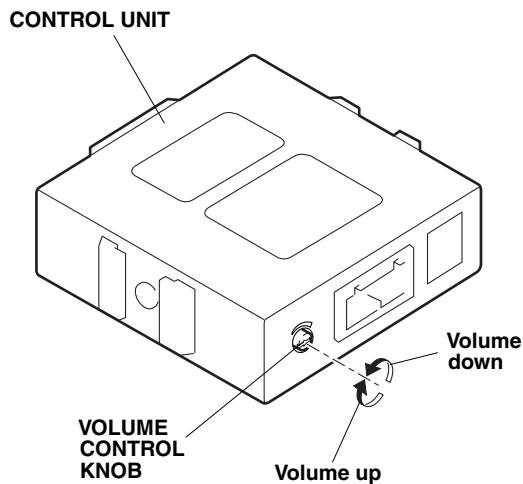

771108AB