



INSTALLATION INSTRUCTIONS

Accessory
RUNNING BOARDS
P/N 08L33-TX4-200A

Application
2017 RDX

Publications No.
VERSION 1
Issue Date
FEB 2016

PARTS LIST

Left running board

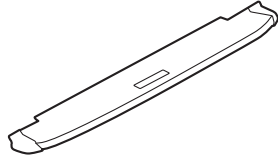

Right running board

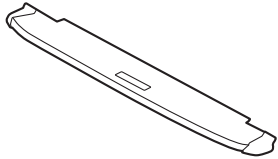

2 Brackets A

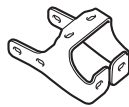

2 Brackets B

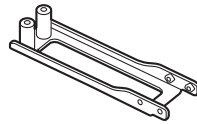

2 Brackets C

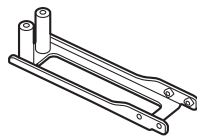

32 Flange bolts, 8 x 20 mm

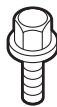

4 Flange bolts, 8 x 65 mm

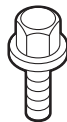

4 Flange bolts, 8 x 80 mm

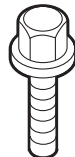

TOOLS AND SUPPLIES REQUIRED

Ratchet

10 mm, 12 mm, and 13 mm Sockets

Torque wrench

Drill

3 mm, 6 mm, 8 mm, and 10 mm Drill bits

30 mm Hole saw

Eye protection (face shield, safety goggles, etc.)

Pushpin

File

The following tools are available through the Honda Tool and Equipment Program. On the iN, click on: Service > Service Bay > Tool and Equipment Program, then enter the number under "Search". Or, call 888-424-6857.

- Air saw (T/N AT192A)
- Trim Tool set (T/N SOJATP2014)

Illustration of the Running Boards on the Vehicle

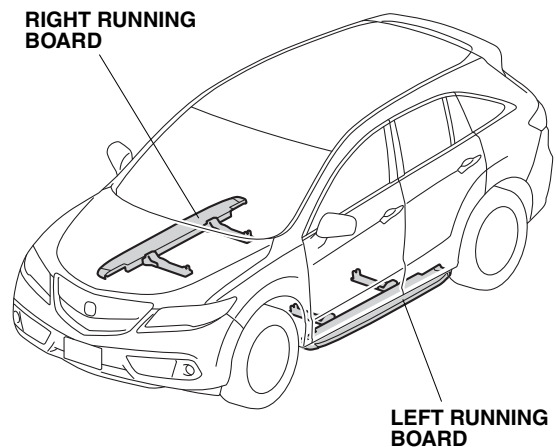

QD32001AA

INSTALLATION

Client Information: The information in this installation instruction is intended for use only by skilled technicians who have the proper tools, equipment, and training to correctly and safely add equipment to your vehicle. These procedures should not be attempted by “do-it-yourselfers.”

NOTE:

- Do not damage the paint finish.
1. Raise the vehicle off the ground and support it as shown in the Service Manual.

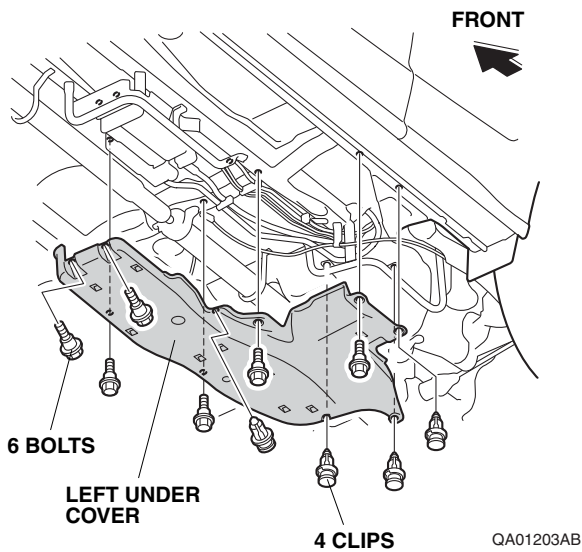

2. Remove the left under cover.

3. Remove the right under cover.

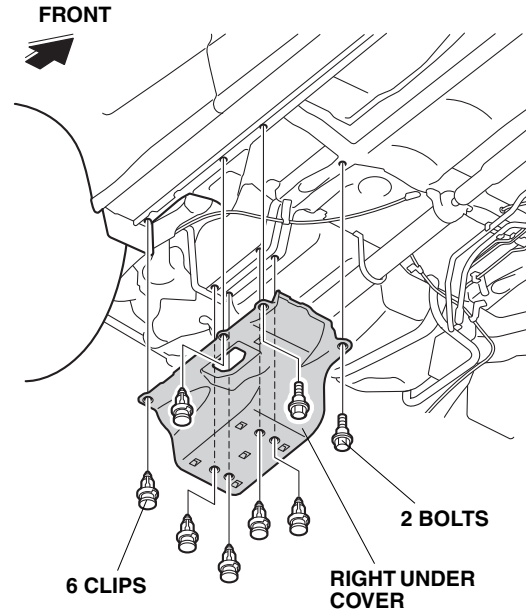

QA01204AB

4. Using a pushpin, pierce eight scribe marks on the left under cover.

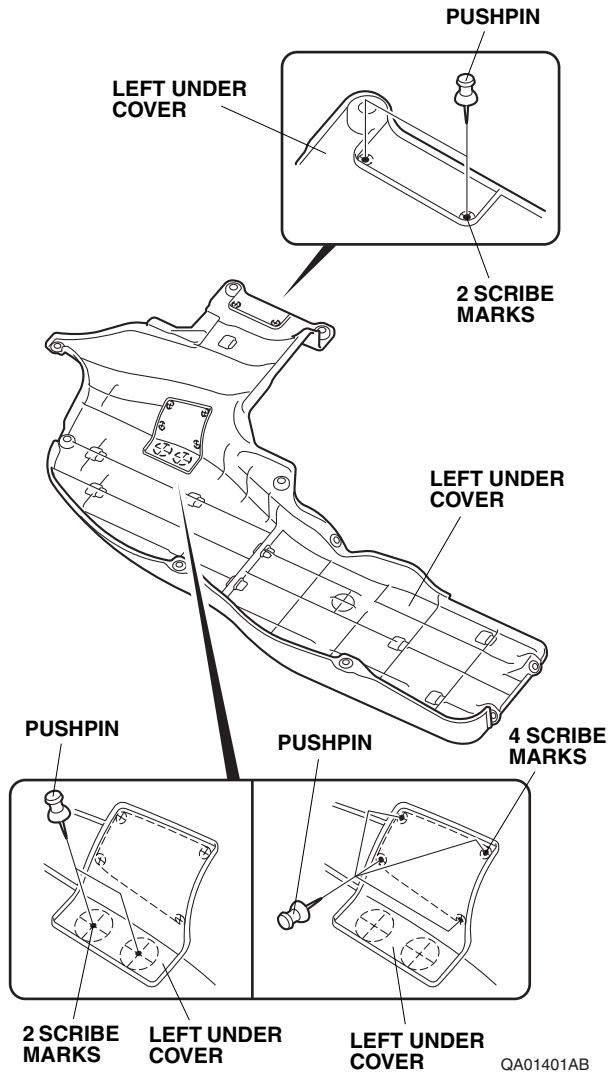

5. While wearing eye protection, drill the eight piercings in the left under cover with a 3 mm drill bit.

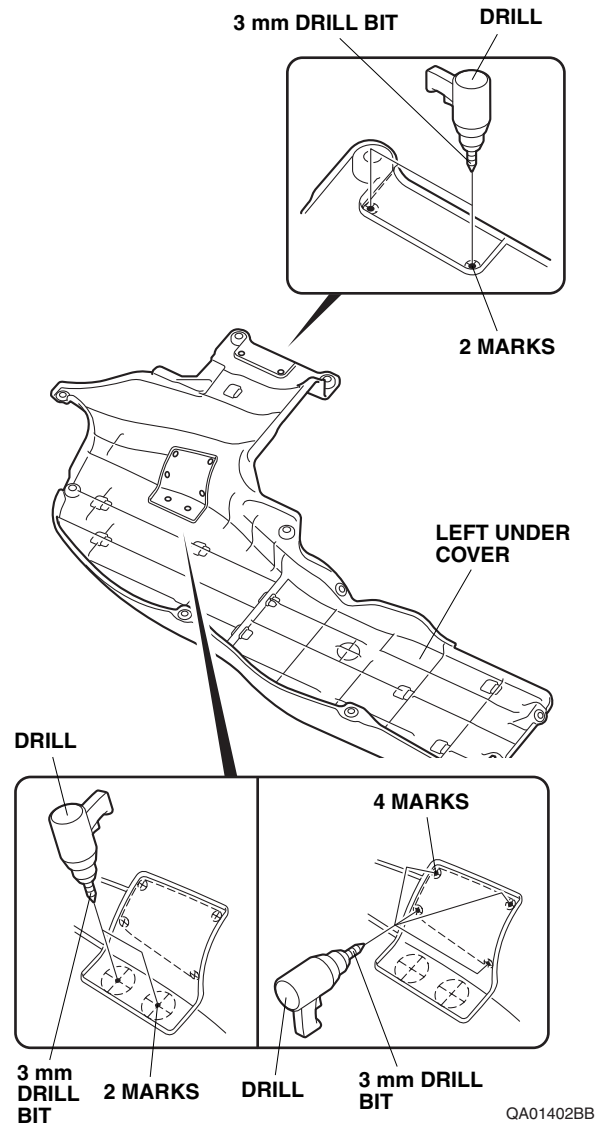

6. Enlarge six holes made in the left under cover in step 5 with a 6 mm drill bit, with an 8 mm drill bit, and finish with a 10 mm drill bit.

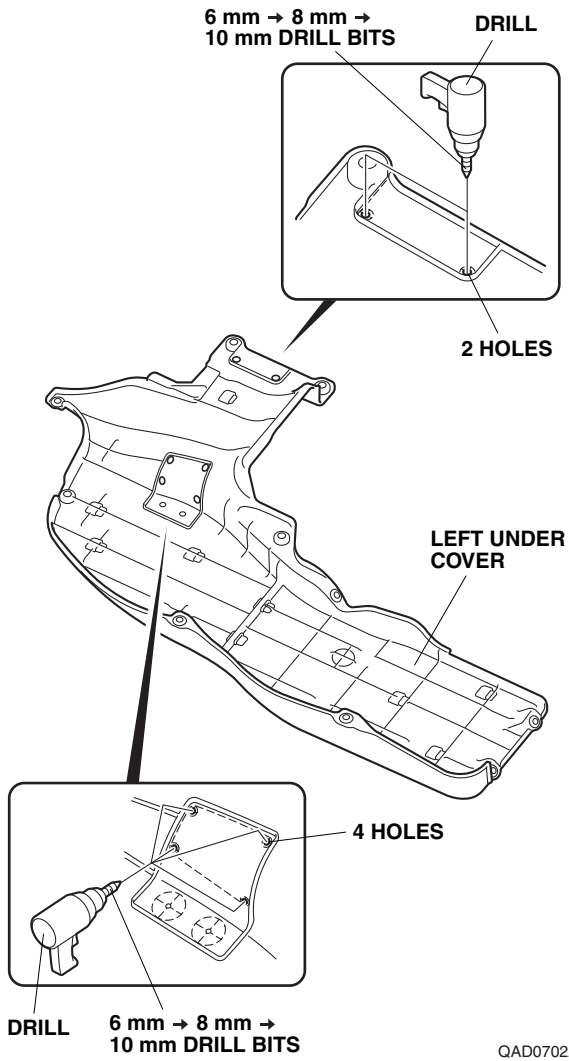

7. Enlarge two holes made in the left under cover in step 5 with a 30 mm hole saw. Remove any burrs.

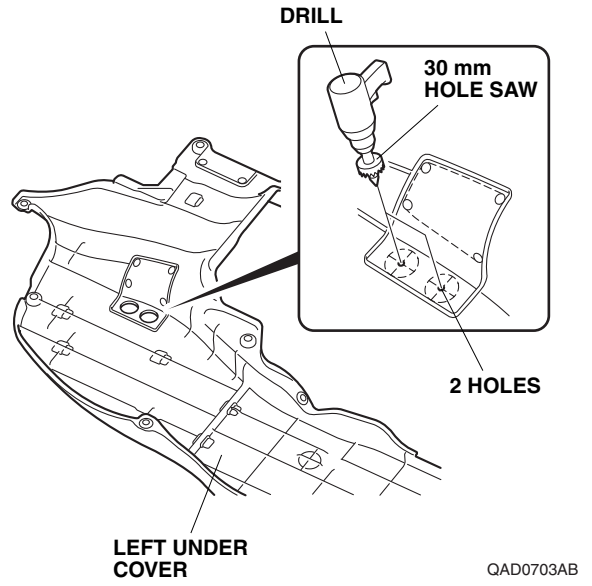

8. Using an air saw, cut along the scribe lines on the left under cover as shown. Remove any burrs.
NOTE: Do not cut the rib.

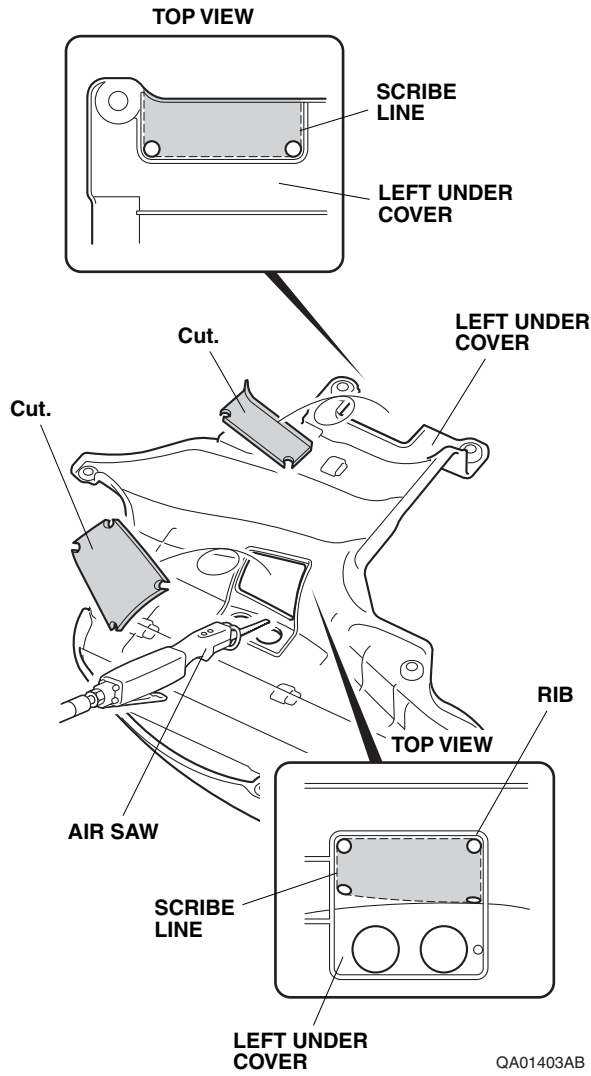

9. Using a pushpin, pierce four scribe marks on the right under cover.

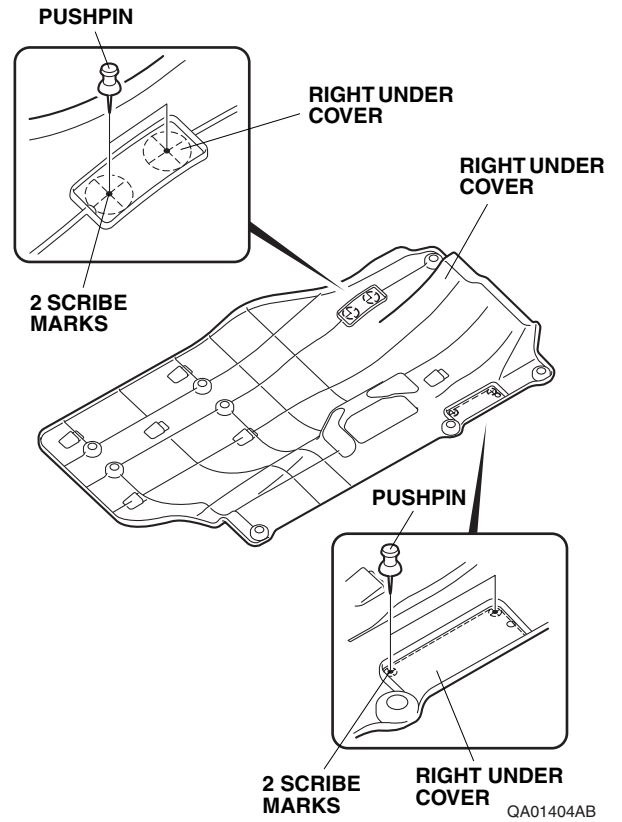

10. While wearing eye protection, drill the four piercings in the right under cover with a 3 mm drill bit.

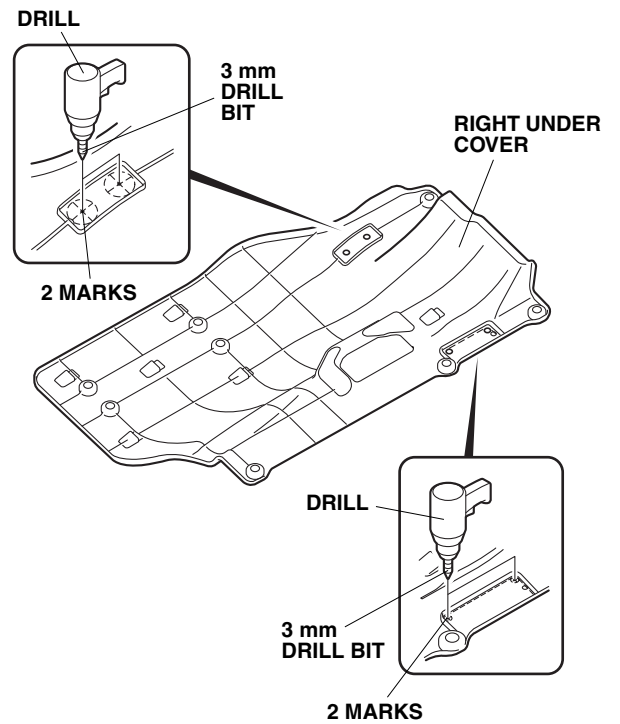

11. Enlarge two holes made in the right under cover in step 10 with a 6 mm drill bit, with an 8 mm drill bit, and finish with a 10 mm drill bit.

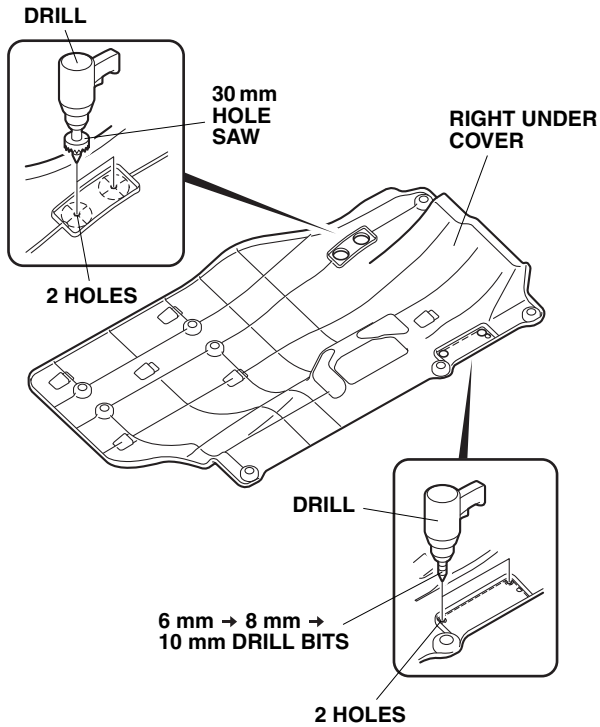

QAD0704AB

12. Enlarge two holes made in the right under cover in step 10 with a 30 mm hole saw. Remove any burrs.

13. Using an air saw, cut along the scribe line on the right under cover as shown. Remove any burrs.

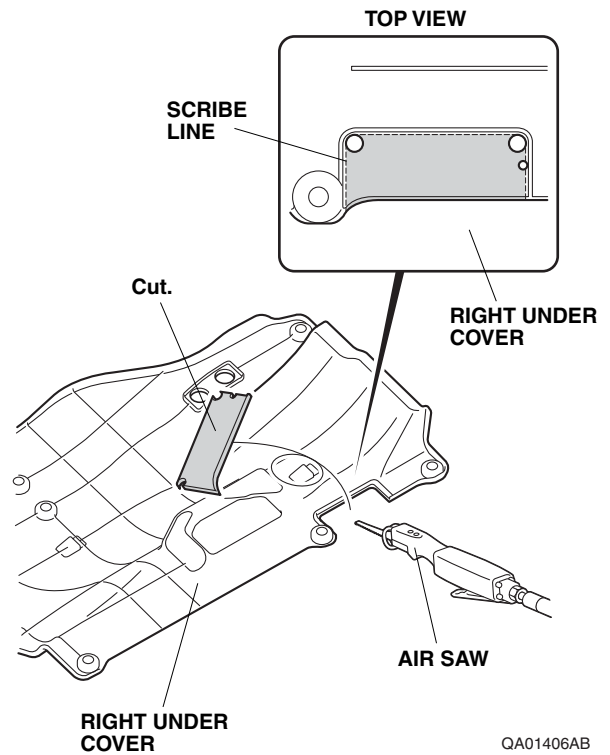

QA01406AB

14. Reinstall the left and right under covers.
15. Secure the two brackets A to the vehicle panel with four loosely installed 8 x 20 mm flange bolts.

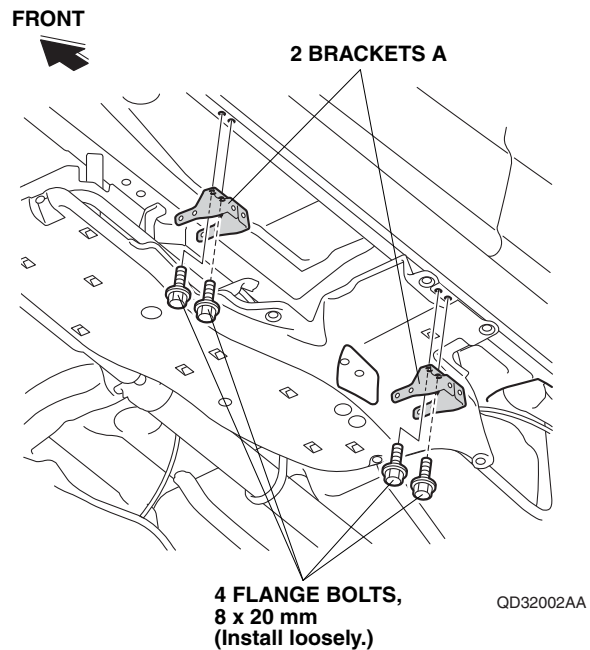

QD32002AA

16. Secure the bracket B and bracket C to the vehicle panel with two loosely installed 8 x 65 mm flange bolts and two loosely installed 8 x 80 mm flange bolts. Make sure to install the bracket B and bracket C in the correct positions.

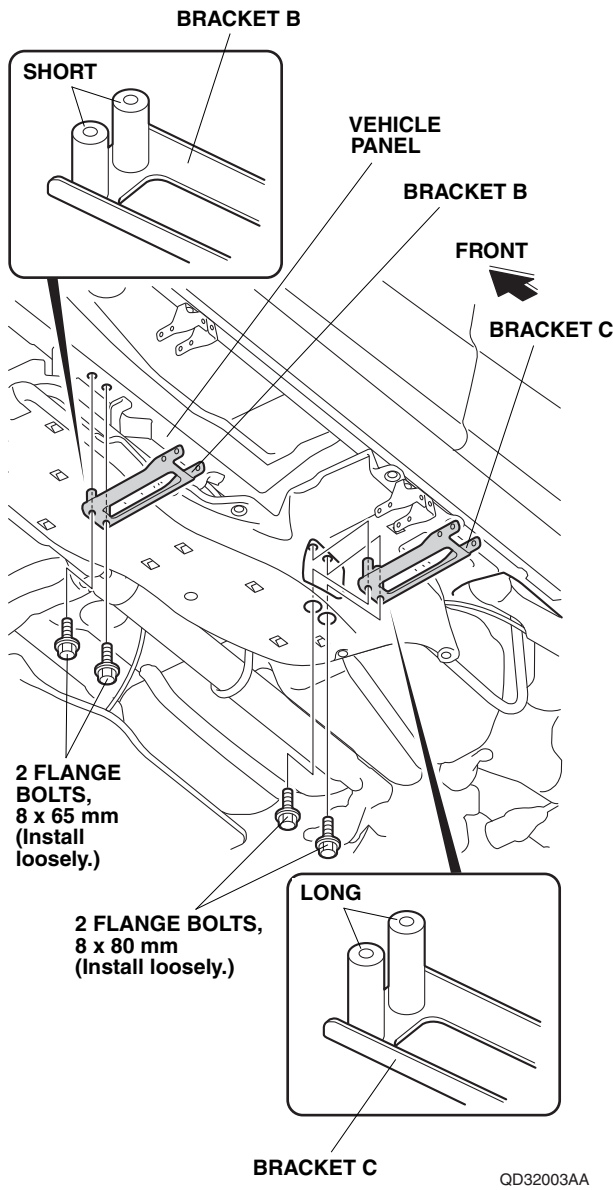

17. Secure the bracket B and bracket C to the brackets A with eight loosely installed 8 x 20 mm flange bolts.

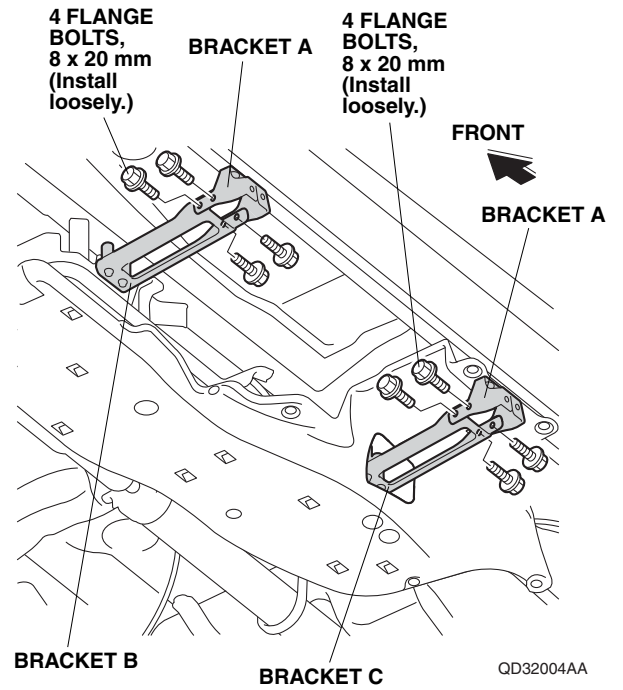

18. Secure the left running board to brackets A with four loosely installed 8 x 20 mm flange bolts.
NOTE: Have an assistant help you when installing the running board.

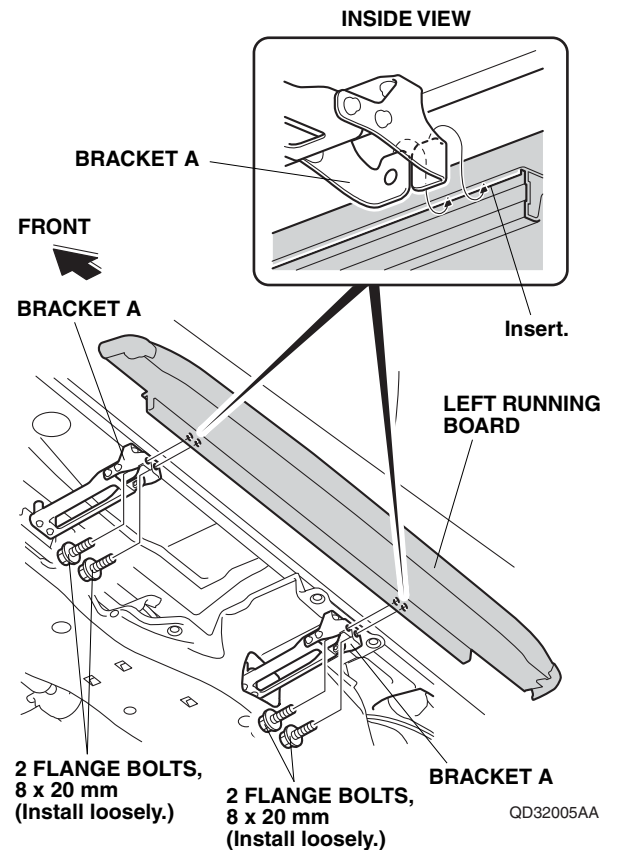

19. Tighten the four 8 x 20 mm flange bolts loosely secured in step 15. Torque the flange bolts to 22 N·m (16 lb·ft).

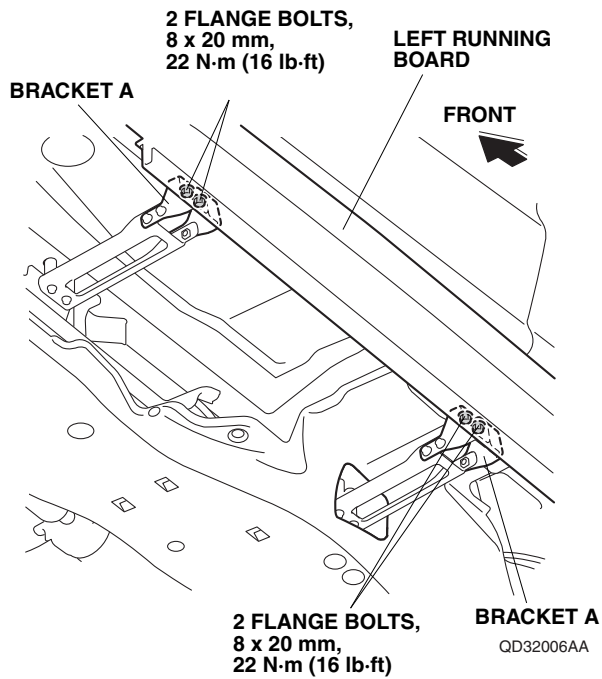

21. Tighten the four 8 x 20 mm flange bolts loosely secured in step 18. Torque the flange bolts to 22 N·m (16 lb·ft).

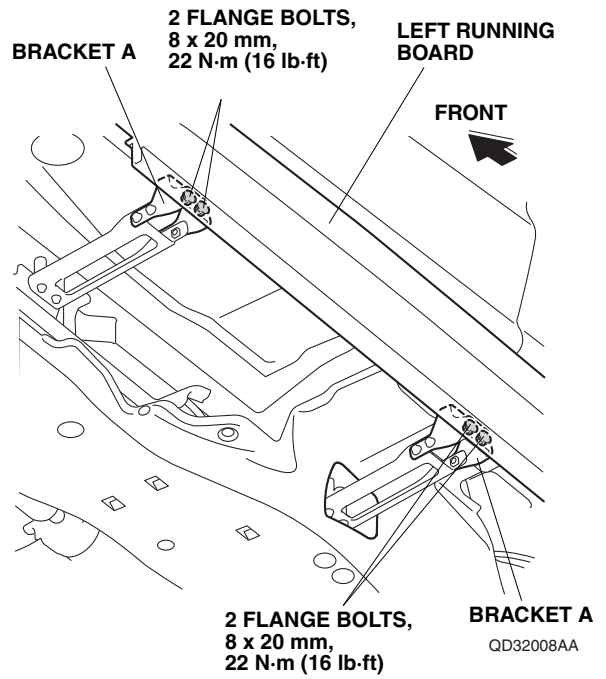

20. Tighten the two 8 x 65 mm flange bolts and two 8 x 80 mm flange bolts loosely installed in step 16. Torque the flange bolts to 22 N·m (2.2 kgf·m, 16 lbf·ft).

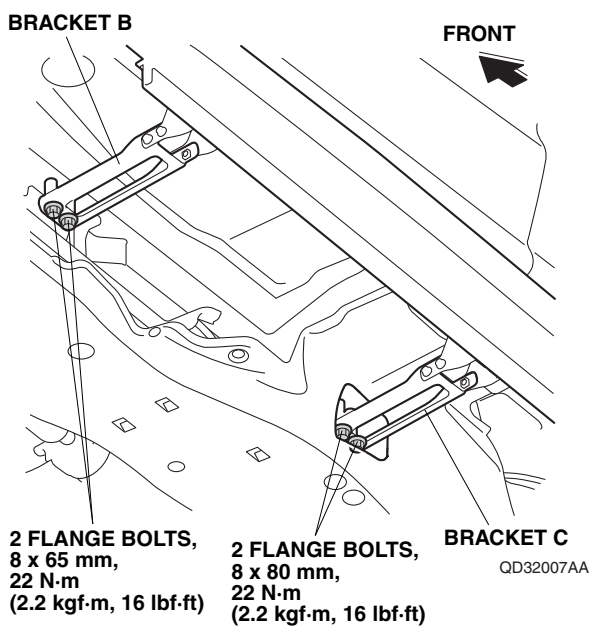

22. Tighten the eight 8 x 20 mm flange bolts loosely installed in step 17. Torque the flange bolts to 22 N·m (2.2 kgf·m, 16 lbf·ft).

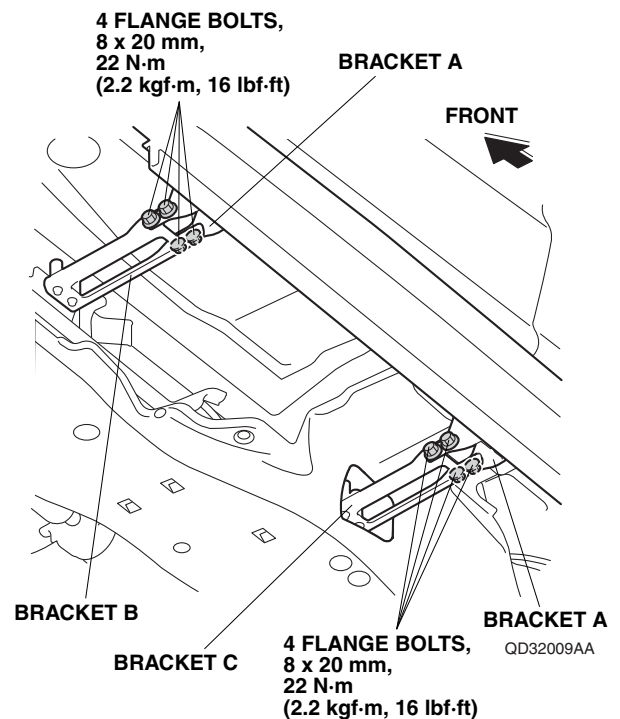

23. Visually check that the left running board is installed parallel to the vehicle.

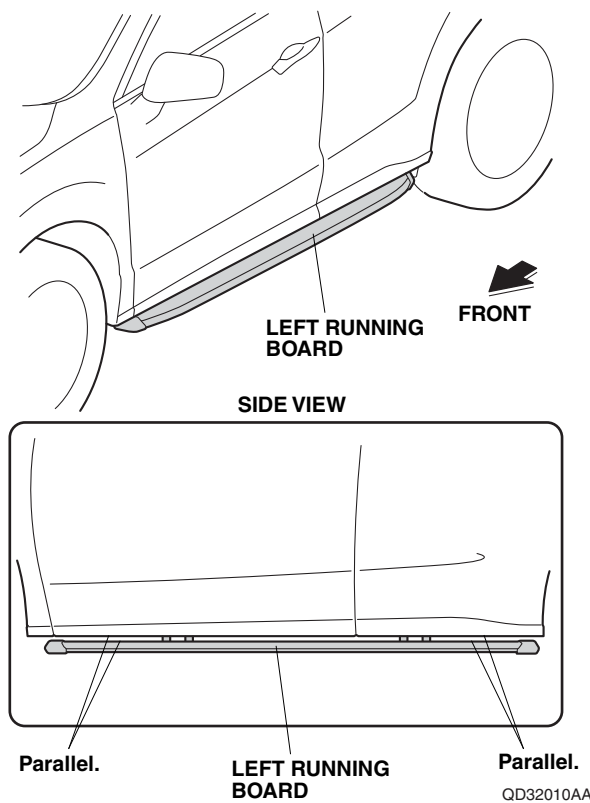

24. Repeat steps 15 through 23 on the right side of the vehicle.