

PARTS LIST

Backup Sensor Kit

Control unit

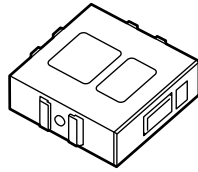

Buzzer

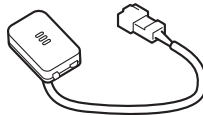

Left corner sensor clip (White)

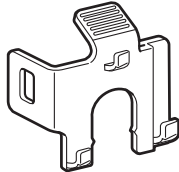

Right corner sensor clip (Black)

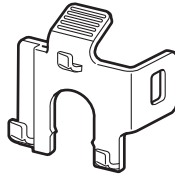

Left center sensor clip (White)

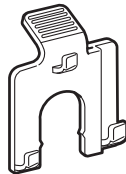

Right center sensor clip (Black)

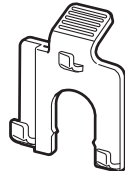

Backup sensor harness

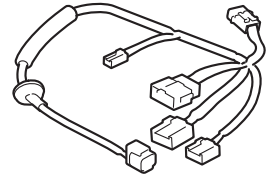

Subharness

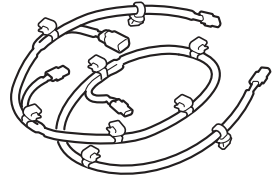

Control unit bracket



Grommet



Self-tapping screw, 5 x 16 mm



6 Wire ties

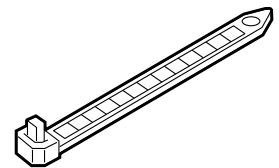

Wire tie with clip

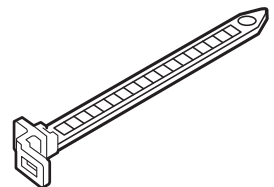

2 Self-tapping screws, 4 x 14 mm



2 Washers



Fuse label

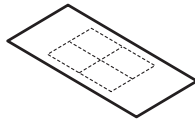

Accessory User's Information Manual

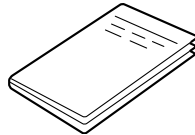

Right corner sensor

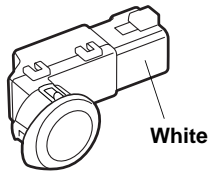

Left corner sensor (with Yellow dot)

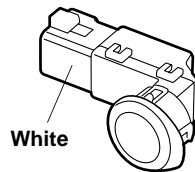

Right center sensor

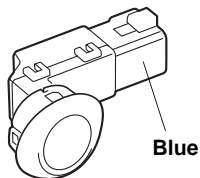

Left center sensor (with Yellow dot)

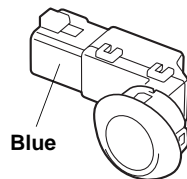

TOOLS AND SUPPLIES REQUIRED

Phillips screwdriver

Small flat-tip screwdriver

Ratchet

8 mm and 10 mm Sockets

Pushpin

Eye protection (face shield, safety goggles, etc.)

Drill

3 mm and 5 mm Drill bits

16 mm, 24 mm, and 26 mm Hole saws (T/N AKS052507)

Debur tool (T/N DEBUR300)

Piece of wire

Tape measure

Felt-tip pen

Diagonal cutters

Torque wrench

Blanket

Isopropyl alcohol

Shop towel

Electrical tape

Plastic Trim Tool (T/N SILTRIMTL 10)

Illustration of the Backup Sensors on the Vehicle

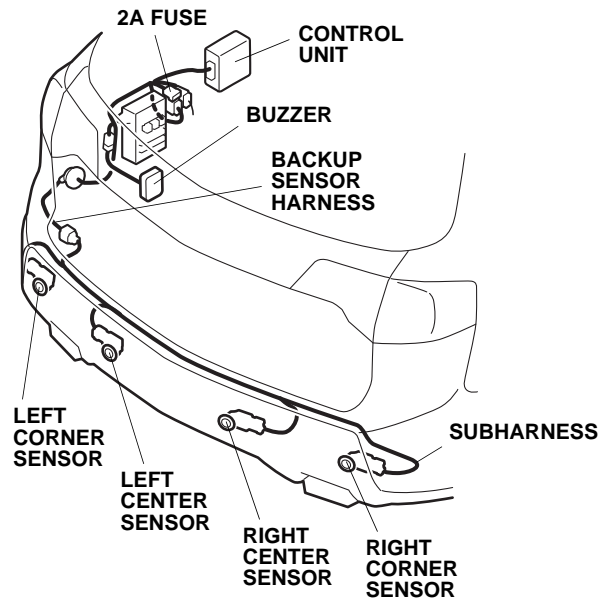

INSTALLATION

Client Information: The information in this installation instruction is intended for use only by skilled technicians who have the proper tools, equipment, and training to correctly and safely add equipment to your vehicle. These procedures should not be attempted by “do-it-yourselfers.”

NOTE:

- Be careful not to damage the rear bumper or other surfaces of the body.
 - Allow the exhaust system to cool down before installing the backup sensors.
1. Make sure you have the anti-theft code for the radio, then write down the frequencies for the preset buttons.
 2. Disconnect the negative cable from the battery.

3. Open the tailgate. Remove four caps, four bolts, 14 self-tapping screws, and six clips from the rear bumper.

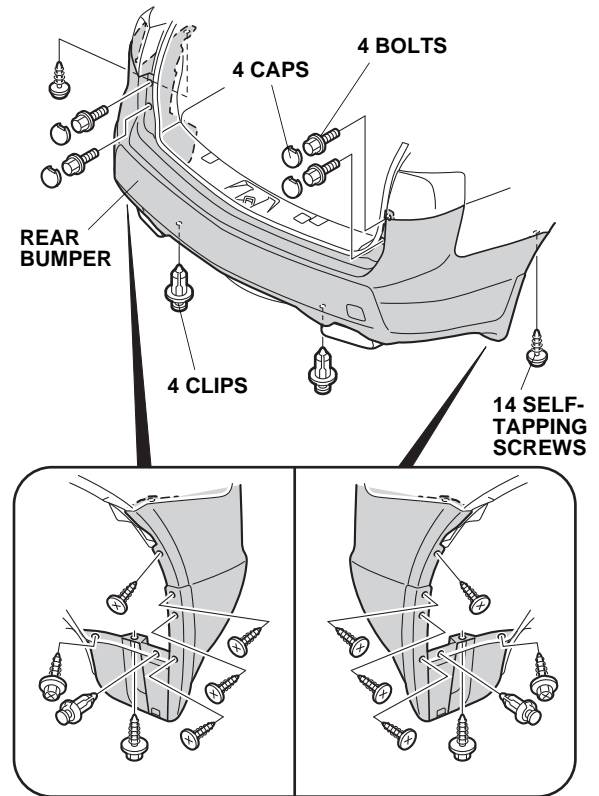

4. With the help of an assistant, remove the rear bumper (four hooks). Place the rear bumper on a blanket to prevent damage.

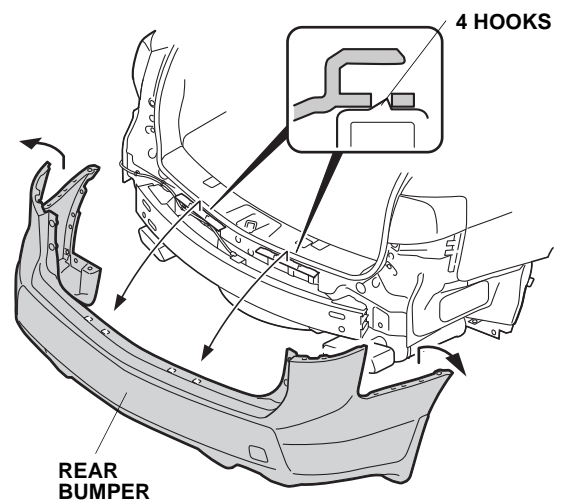

- On the inside of the rear bumper, locate the two preset marks. Using a pushpin, pierce through the rear bumper at the four locations shown.

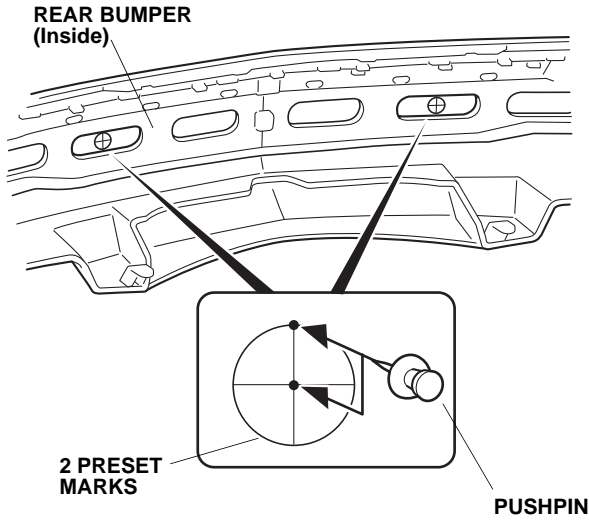

- Working from the outside (painted side) of the bumper, use a 3 mm drill bit to drill four holes in the rear bumper at the pierced holes you made in step 5. Wear eye protection.

NOTE: The top hole must be drilled exactly at the 12 o'clock position for the sensor to operate correctly.

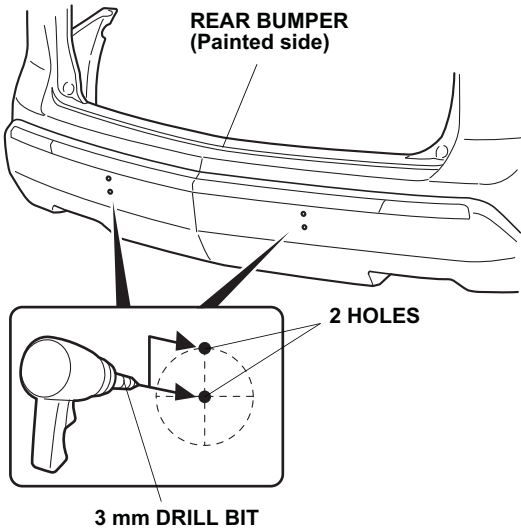

- Enlarge the two lower holes with a 26 mm hole saw. Remove any burrs from the edges of the holes with a debur tool.

NOTE: The sensors will not install properly if there are burrs.

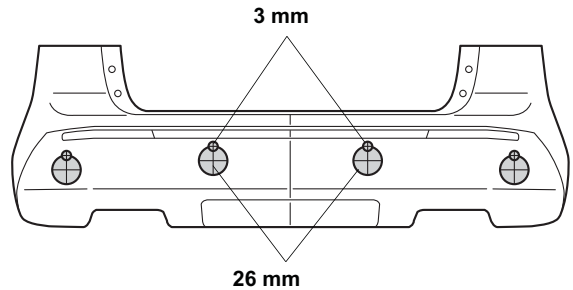
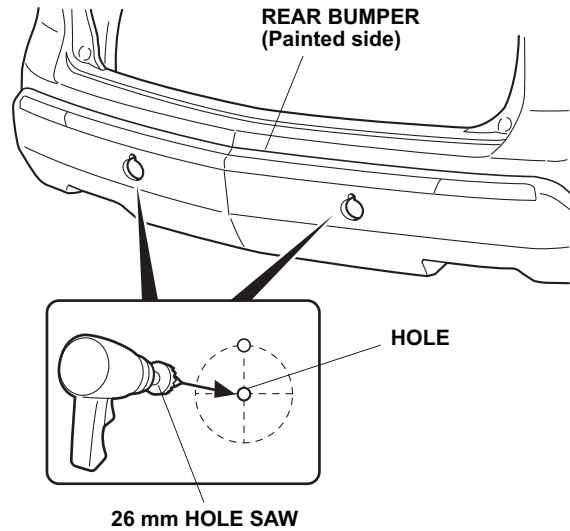

- On the inside of the rear bumper, locate the two preset marks. Using a pushpin, pierce through the rear bumper at the four locations shown.

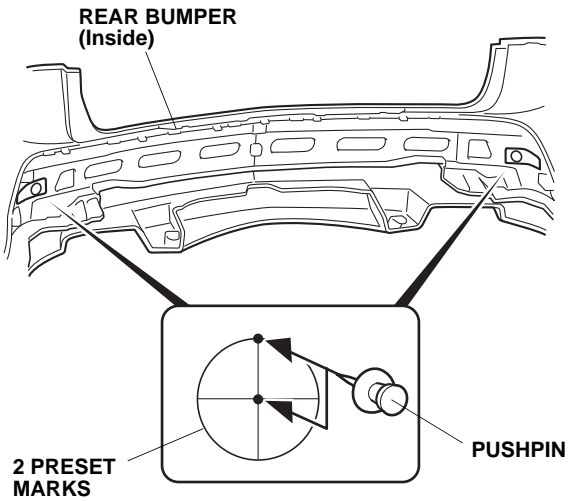

- Working from the outside (painted side) of the bumper, use a 3 mm drill bit to drill four holes in the rear bumper at the pierced holes you made in step 6. Wear eye protection.

NOTE: The top hole must be drilled exactly at the 12 o'clock position for the sensor to operate correctly.

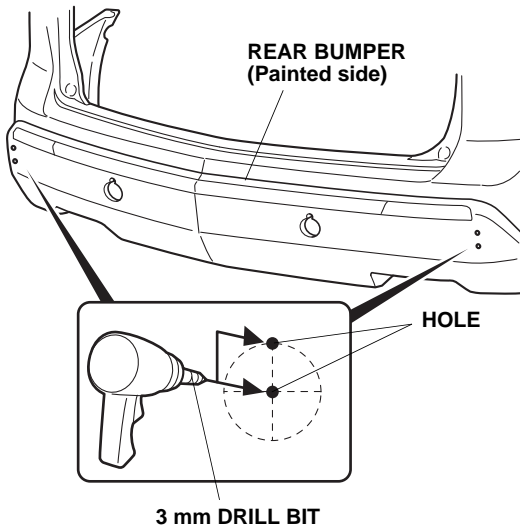

- Enlarge the two lower holes with a 24 mm hole saw. Remove any burrs from the edges of the holes with a debur tool.

NOTE: The sensors will not install properly if there are burrs.

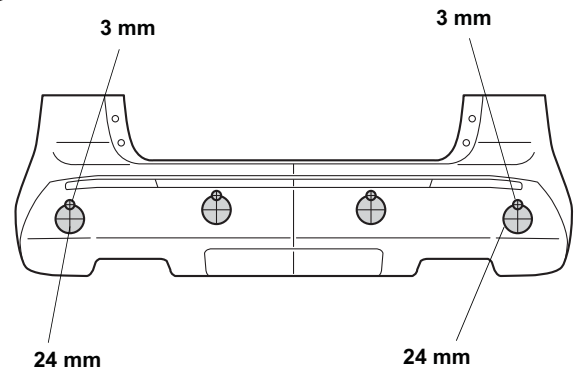
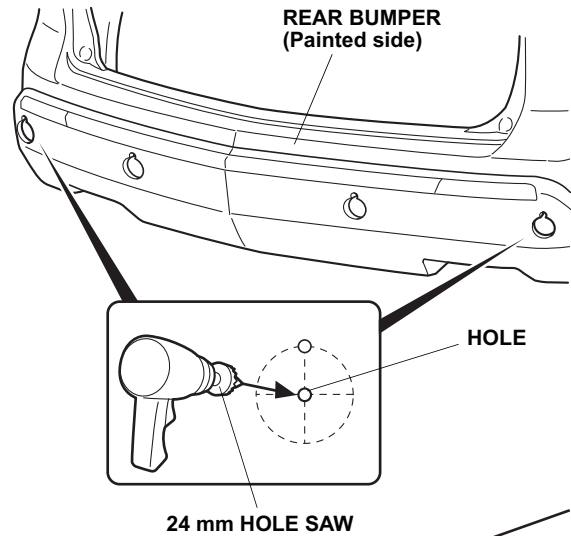

11. Install the center sensors and corner sensors into the rear bumper.

NOTE:

- The sensor detent must be at the 12 o'clock position for the sensor to operate correctly.
- The left center sensor and left corner sensor have yellow dots.

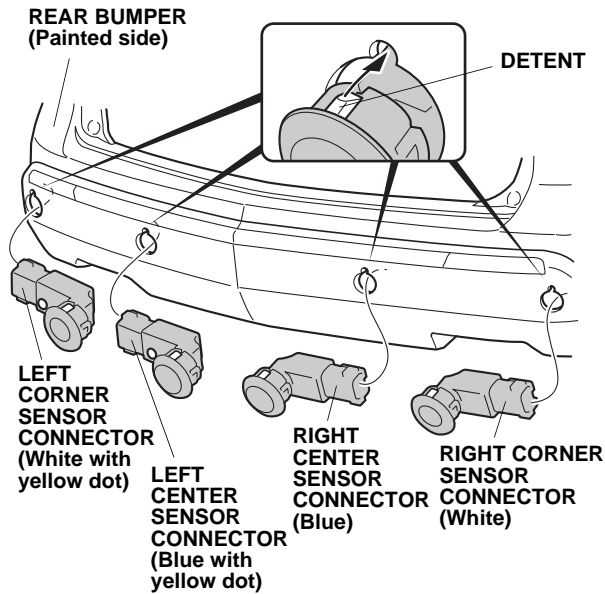

12. Install the right corner sensor clip (black), the left corner sensor clip (white), the right center sensor clip (black), and the left center sensor clip (white).

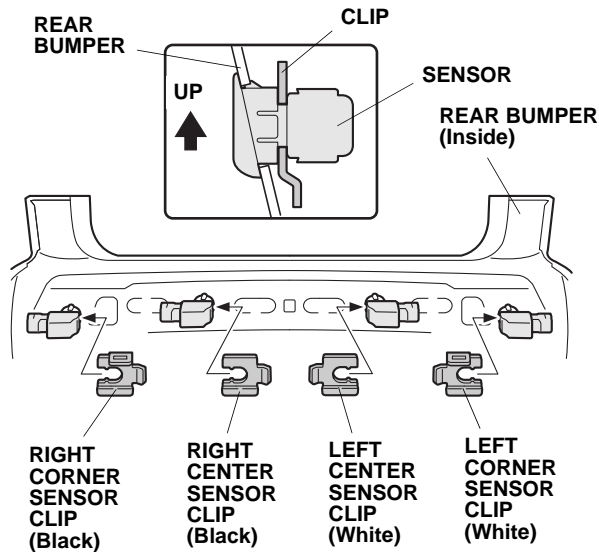

13. Route the subharness along the rear bumper. Plug the subharness 2-pin connectors into the sensors.

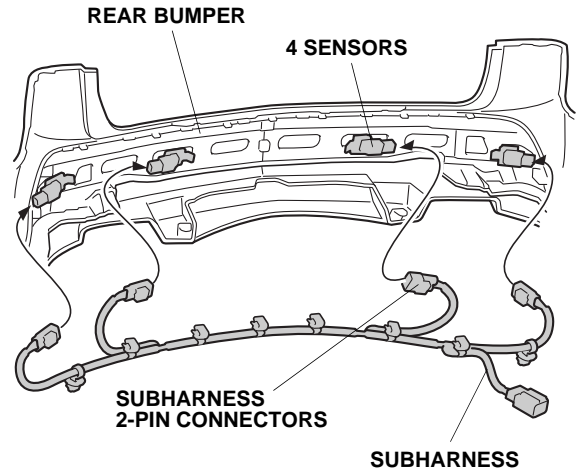

14. Secure the seven subharness clips to the seven rear bumper tabs.

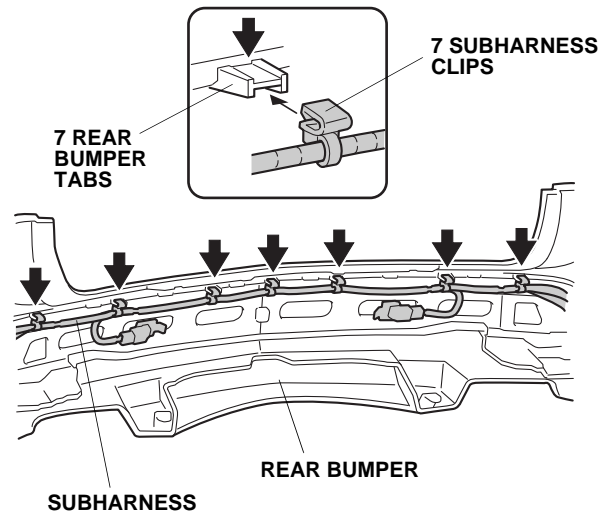

15. Secure the two subharness clips to the left and right corner sensor clips.

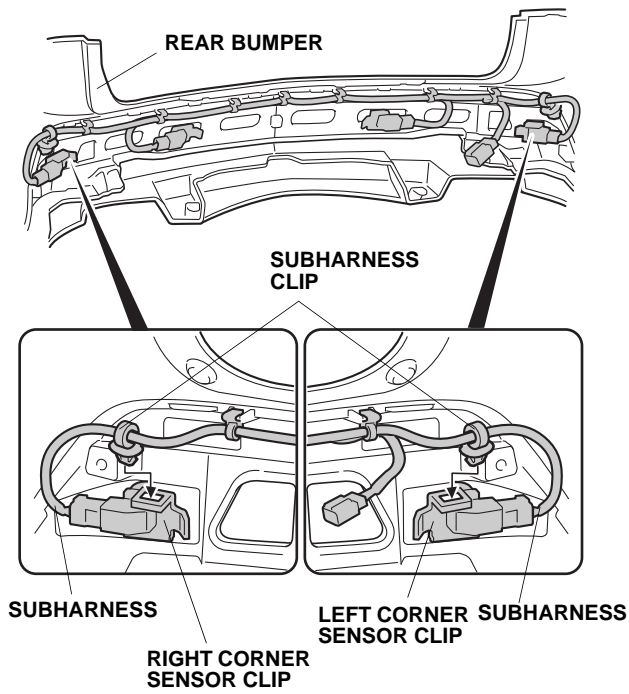

16. Lift up the lock handle and remove the rear cargo floor lid.

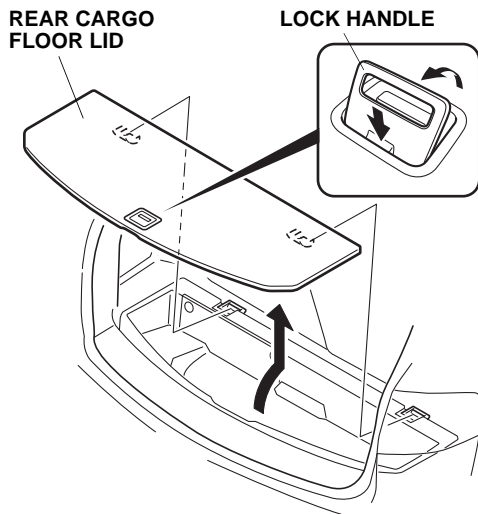

17. Turn the knobs, then remove the cover from the rear cargo tray.

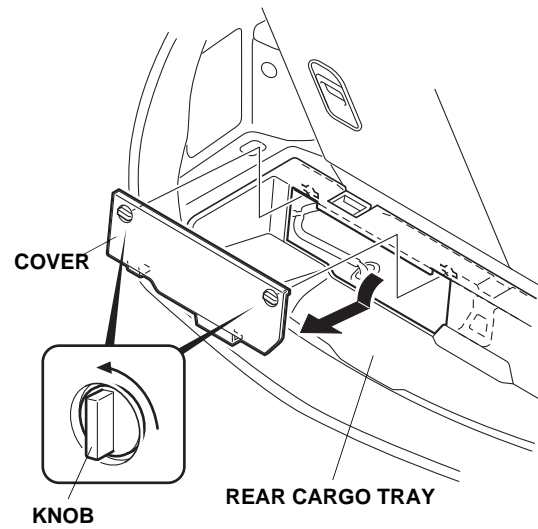

18. Remove the rear trim panel (four retaining tabs and four clips).

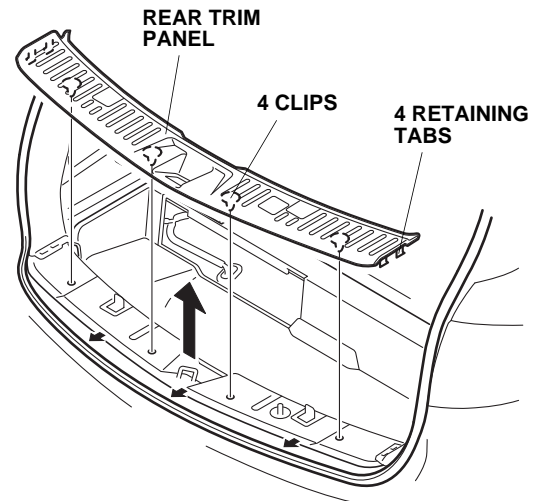

19. Remove the two cargo lid hinges (two self-tapping screws), and remove the rear cargo tray.

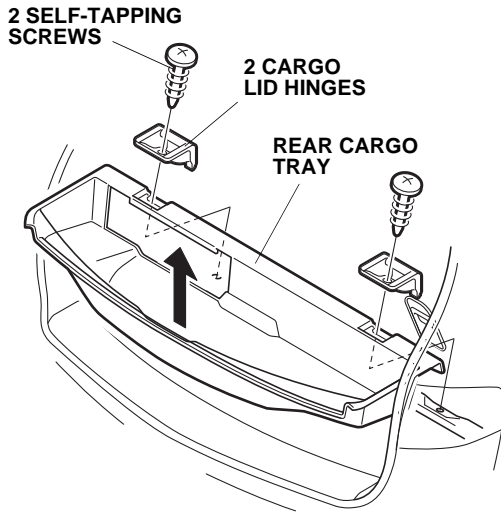

20. Remove the left rear door side sill (three clips and two retaining tabs).

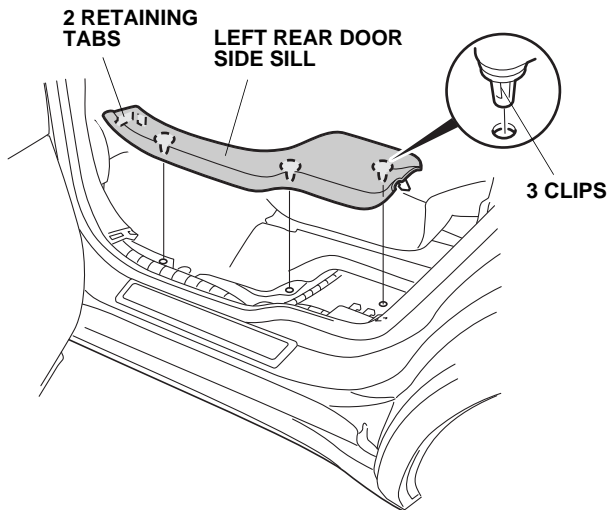

21. Release the two retaining tabs, spread the two seat bolt covers apart and remove the two seat bolt covers from the third row left seat frame.

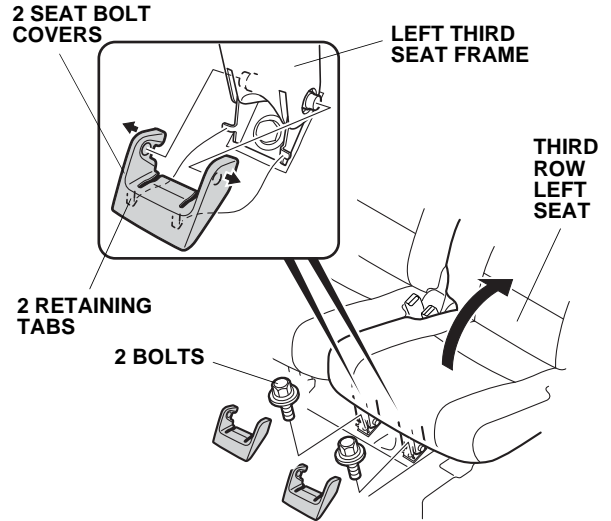

22. Remove the two bolts that fasten the third row left seat to the floor. Raise the third row left seat cushion.
23. Remove the four rear bolts that fasten the third row left seat to the floor. Remove the third row seat belt buckle.

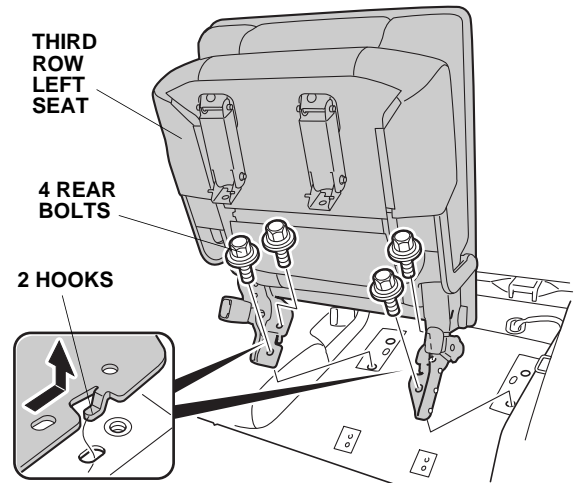

24. Release the two hooks by moving the third row left seat rearward, then remove the third row left seat.

25. Using a small flat-tip screwdriver, open the lower tie-down hook covers. Remove the two tie-down hooks (one screw for each).

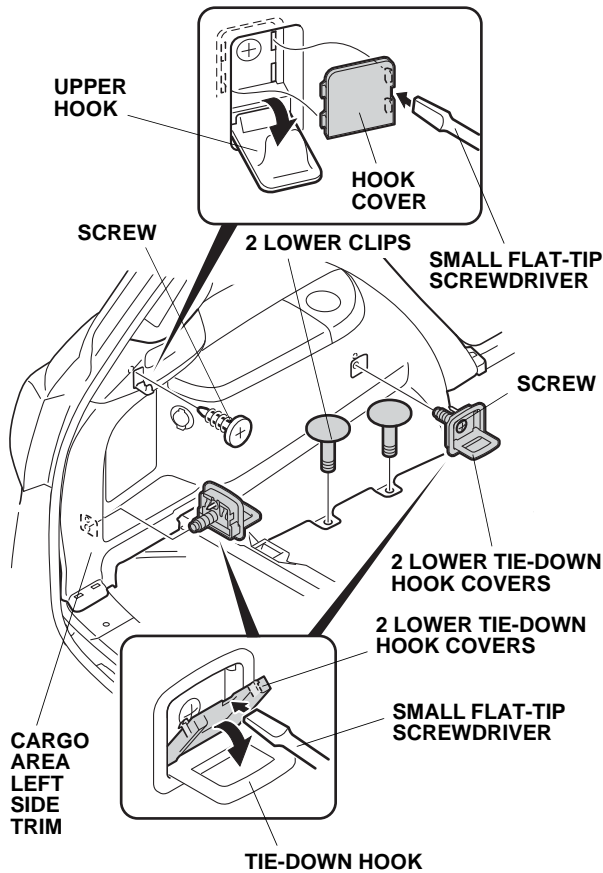

26. Using a small flat-tip screwdriver, remove the hook cover from the upper hook. Remove the screw above the hook.
27. Remove two lower clips from the cargo area left side trim.

28. Remove the tailgate weatherstrip and left rear door weatherstrip around the cargo area left side trim.

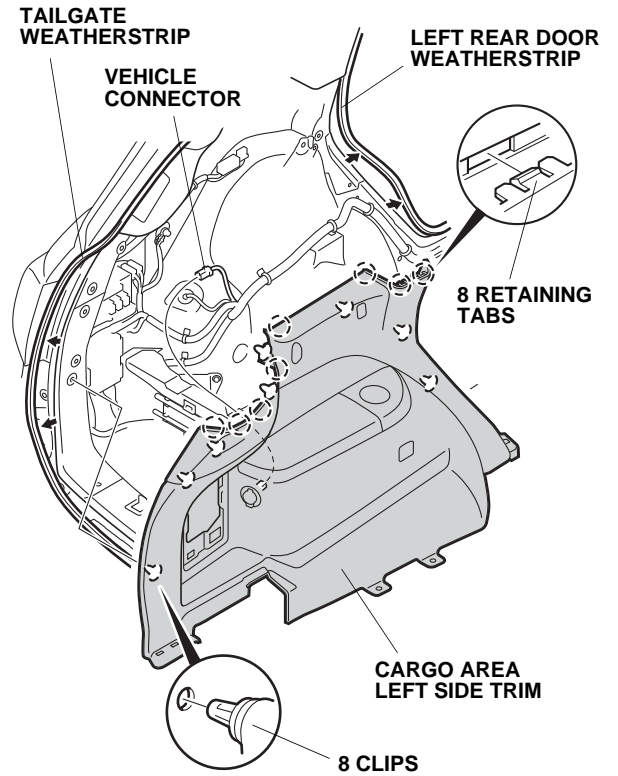

29. Remove the cargo area left side trim (eight clips, eight retaining tabs, and unplug the vehicle connector).
30. Locate and remove the body panel grommet from the left rear bumper area.

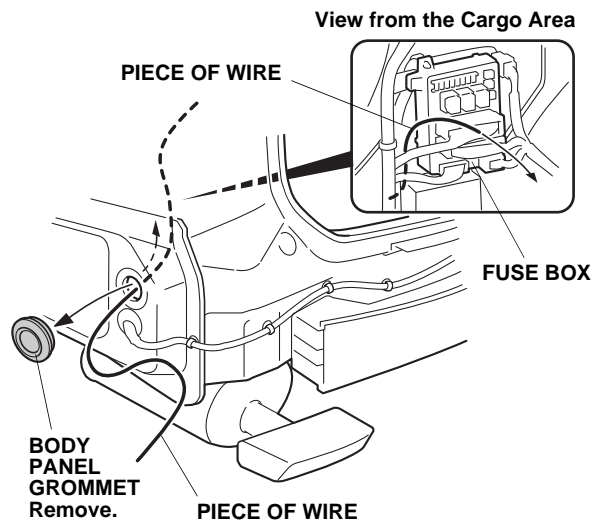

31. Route a piece of wire through the grommet hole.

32. Tape the backup sensor harness to the wire.

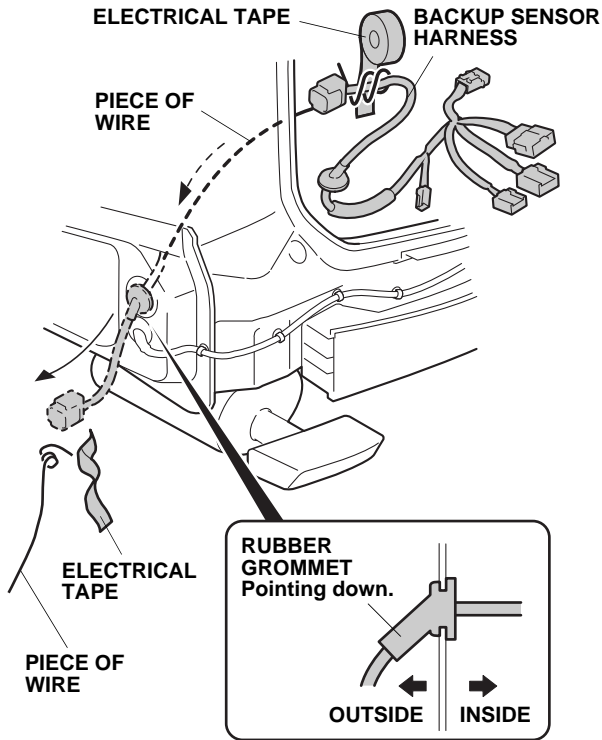

33. Gently pull the harness through the vehicle outer panel, and seat the rubber grommet into the body panel with the harness pointing down. Remove the harness from the piece of wire.
34. Secure the backup sensor harness 8-pin connector to the vehicle harness using a wire tie with clip.

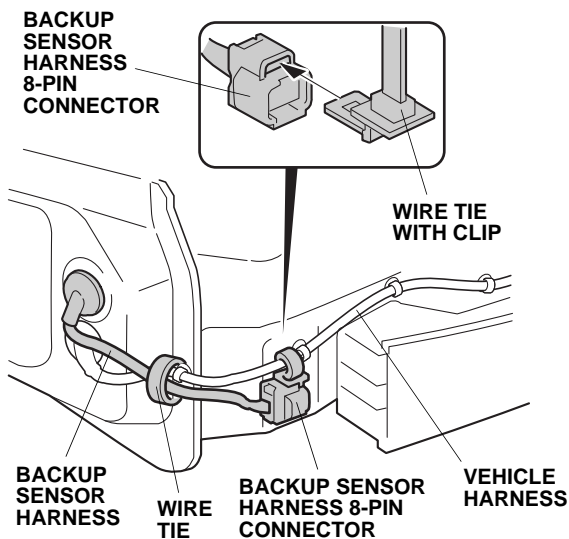

35. Secure the backup sensor harness to the vehicle harness using a wire tie.

36. Inside the cargo area, unplug the vehicle 20-pin connector. Plug the backup sensor harness 20-pin connector to the vehicle. Plug the vehicle 20-pin connector to the backup sensor harness.

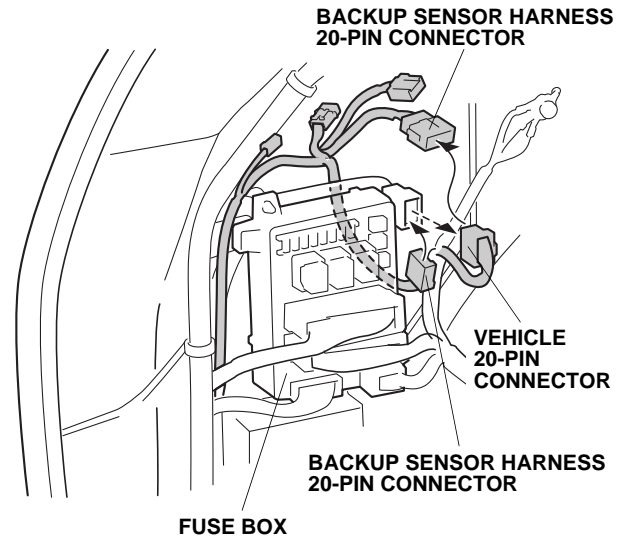

37. Clean the fuse case with isopropyl alcohol. Attach the fuse label (BACKUP SENSOR 2A) to the fuse case.

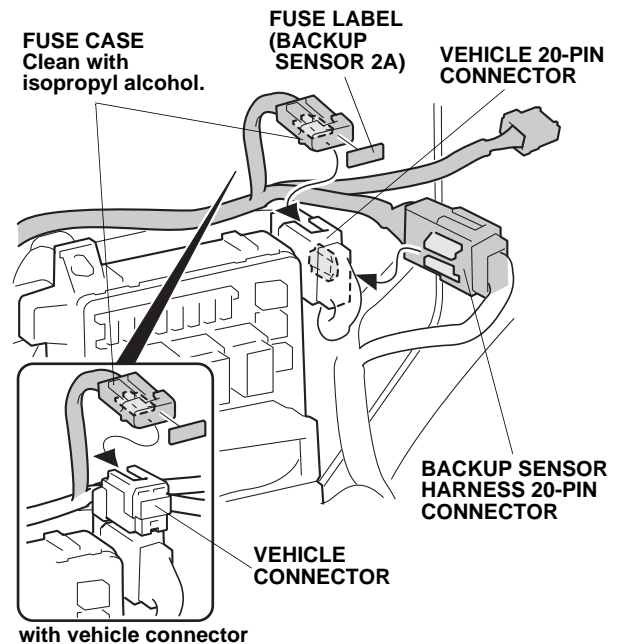

38. Clip the fuse case and backup sensor harness 20-pin connector to the vehicle 20-pin connector.

39. Attach the control unit bracket onto the control unit.

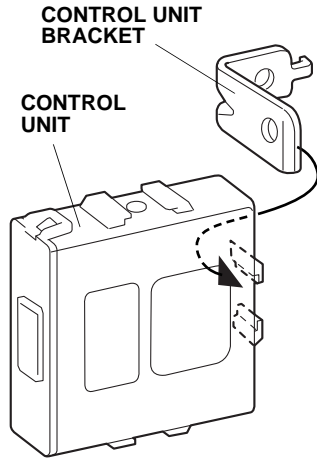

40. Insert the grommet into the hole in the vehicle panel.

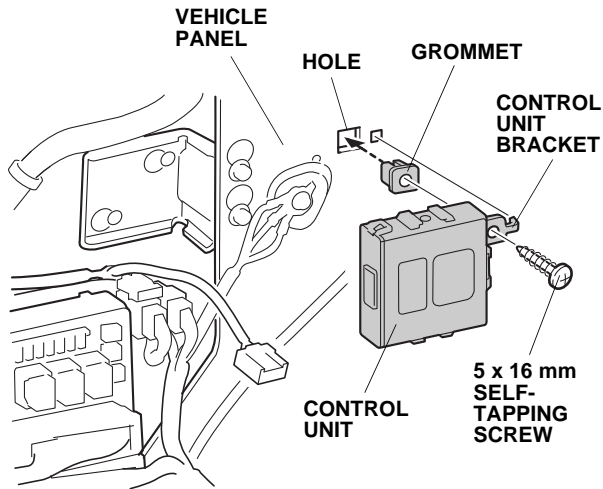

41. Position the control unit bracket on the grommet, and install the 5 x 16 mm self-tapping screw.

42. Plug the backup sensor harness 14-pin connector into the control unit.

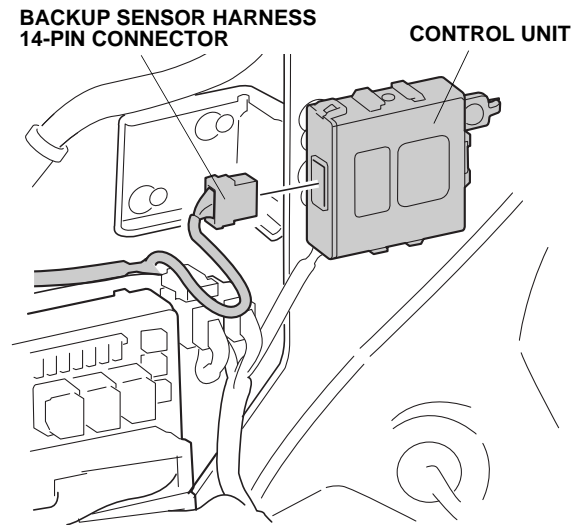

43. Secure the backup sensor harness to the vehicle harness using four wire ties.

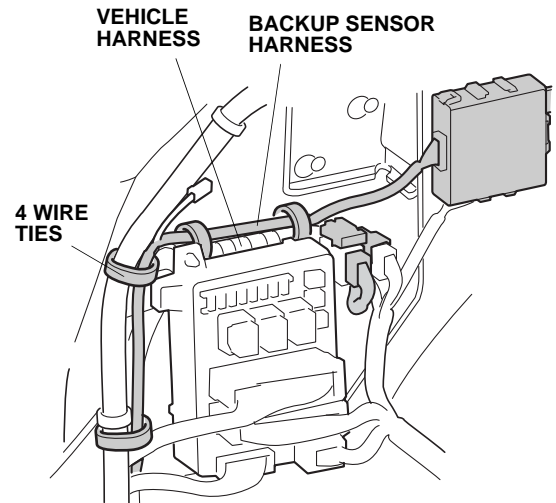

44. Using a tape measure and a felt-tip pen, measure and mark the inside of the cargo area left side trim as shown.

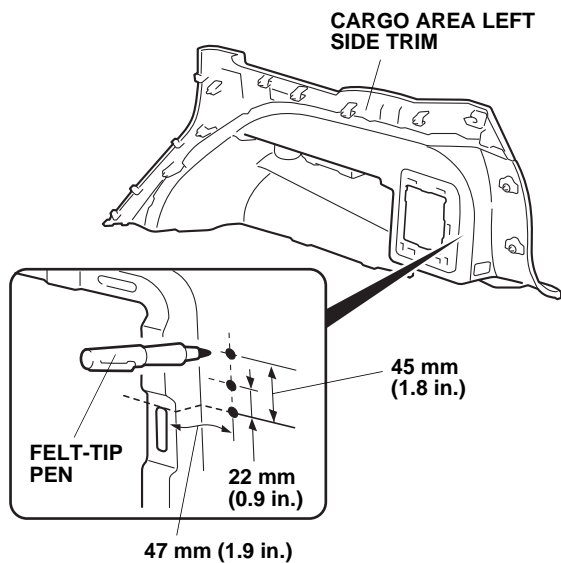

45. Using a pushpin, pierce through the cargo area left side trim at each of the three marks.

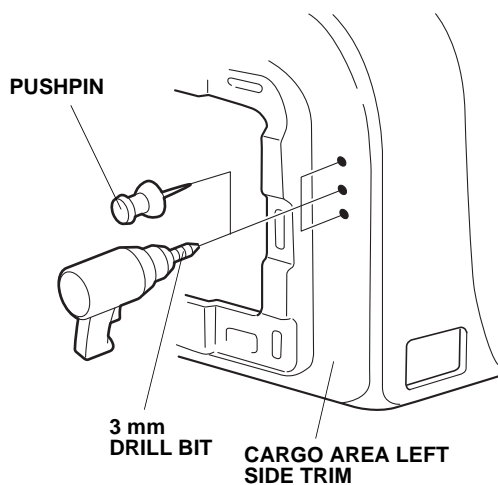

46. While wearing eye protection, drill a 3 mm hole through each of the pierced points.
47. Enlarge the top and bottom holes with a 5 mm bit. Enlarge the center hole to 16 mm using a hole saw. Remove any burrs from the edges of the holes with a file.

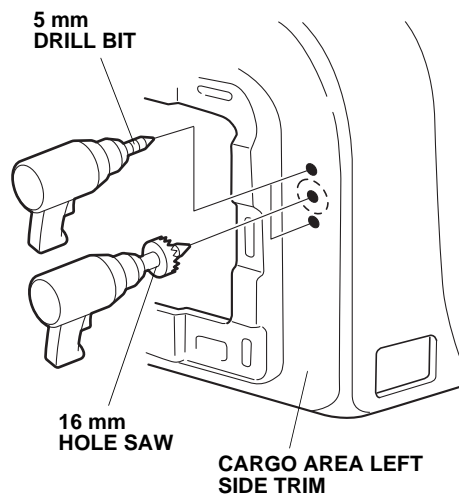

48. Route the buzzer harness through the 16 mm hole. With the buzzer switch facing up, install the buzzer with two 4 x 14 mm self-tapping screws with two washers.

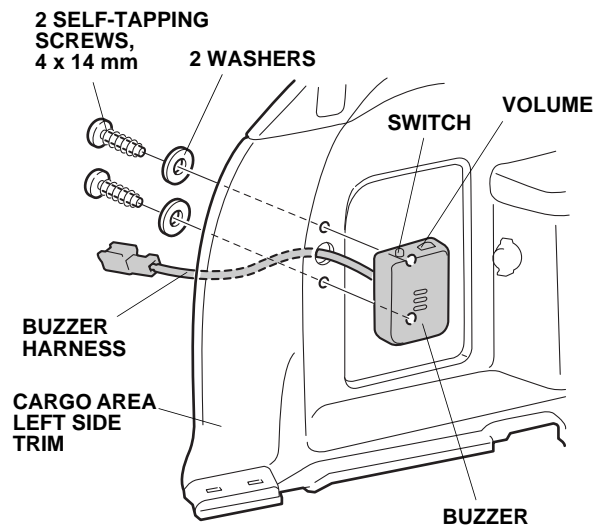

49. Plug the buzzer harness 2-pin connector into the backup sensor harness 2-pin connector. Secure the buzzer harness 2-pin connector to the vehicle harness using one wire tie.

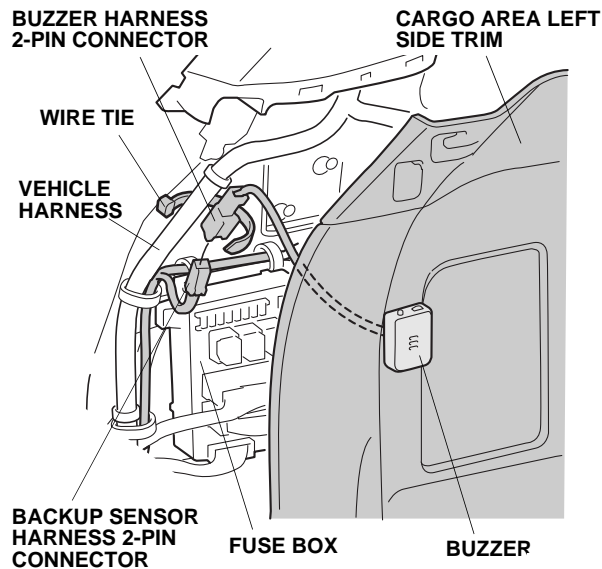

50. Plug in the vehicle connector unplugged in step 29, then reinstall the cargo area left side trim, two lower tie-down hooks, two lower clips, and screw. Check that all clips and retaining tabs are installed securely.

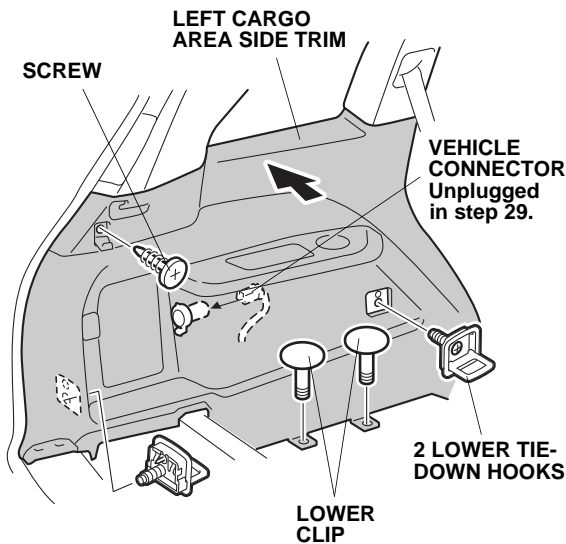

51. With the help of an assistant, plug the subharness connector into the backup sensor harness connector. Reinstall the rear bumper. Check that all clips and retaining tabs are installed securely.

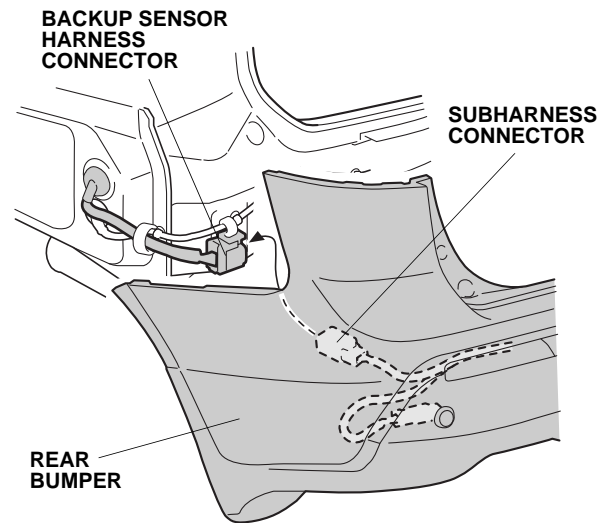

52. Check that all wire harnesses and cables are routed properly and that all connectors are plugged in.
53. Reinstall the third row seat; torque the seat bolts to 41 to 53 N·m (30 to 39 lbf·ft).
54. Reinstall all removed parts. Check that all clips and other fasteners are installed securely.
55. Reconnect the negative cable to the battery. Check that the electrical accessory and electrical systems function properly.
56. Enter the client's radio anti-theft code, and reset the radio station presets.
57. Reset the clock.
58. Make sure the backup sensors work properly as described in the Accessory User's Information Manual supplied with the backup sensor kit.

Buzzer Volume Control

The original volume setting is turned to maximum volume. The volume level can be adjusted by turning the volume control knob on the control unit using a small flat-tip screwdriver.

