



INSTALLATION INSTRUCTIONS

Accessory
BACK-UP SENSORS

Application
2009 TL

Publications No.
BII 39481
Issue Date
SEP 2008

PARTS LIST

Back-up Sensors Attachment Kit
P/N 08V67-TK4-200A

Control unit bracket

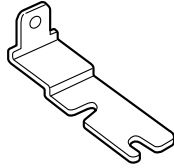

Sensor harness

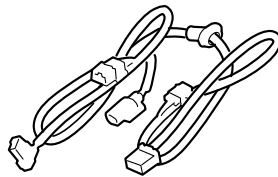

Fuse seal

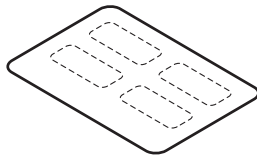

Control unit

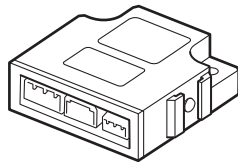

Buzzer

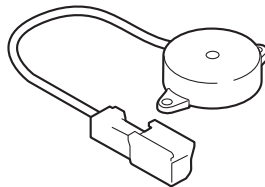

4 Sensor clips

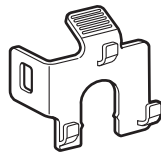

9 Wire ties

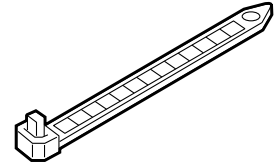

4 Wire ties with clip A

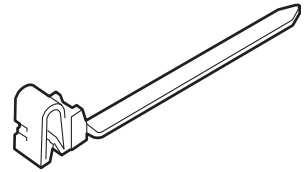

5 Aluminum tapes



Sub harness

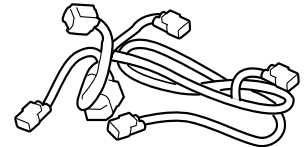

2 Wire ties with clip B

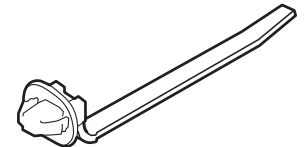

Holder

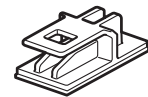

Urethane tape

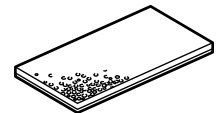

Accessory User's Information Manual

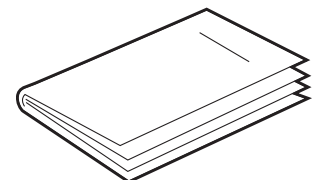

Back-up Sensors Kit

2 Center sensors

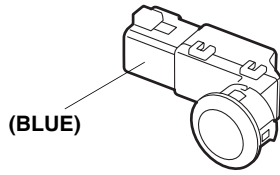

2 Corner sensors

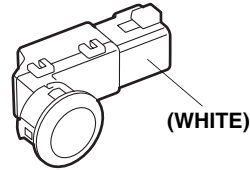

TOOLS AND SUPPLIES REQUIRED

Phillips screwdriver
Flat-tip screwdriver
Small flat-tip screwdriver
Ratchet
10 mm Socket
Scissors
Pushpin
Drill
3 mm Drill bit
24 mm and 26 mm Hole saws
(T/N: AKS052507 hole saw kit)
Eye protection (safety goggles, face shield, etc.)
File
Diagonal cutters
Isopropyl alcohol
Shop towel
Plastic Trim Tool (T/N SILTRIMTL10)
Blanket

Illustration of the Back-up Sensors Installed in the Vehicle

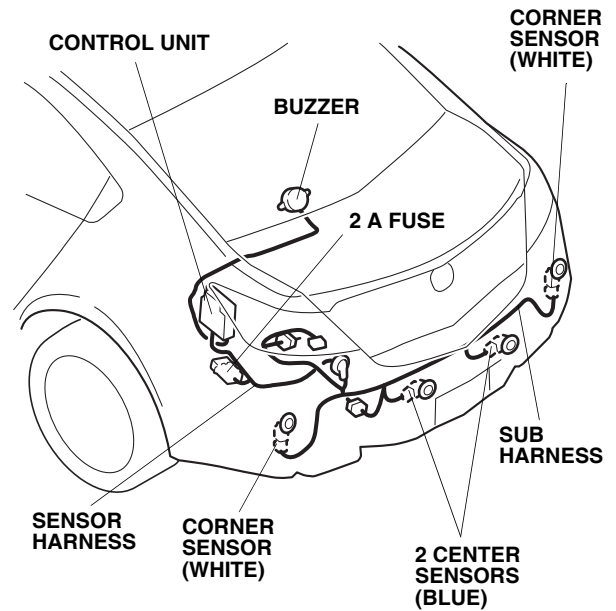

INSTALLATION

Client Information: The information in this installation instruction is intended for use only by skilled technicians who have the proper tools, equipment, and training to correctly and safely add equipment to your vehicle. These procedures should not be attempted by “do-it-yourselfers.”

1. Make sure you have the anti-theft codes for the audio and navigation system (if equipped), then write down the audio presets.
2. Open the hood, and remove the front engine cover (four clips and two hooks).

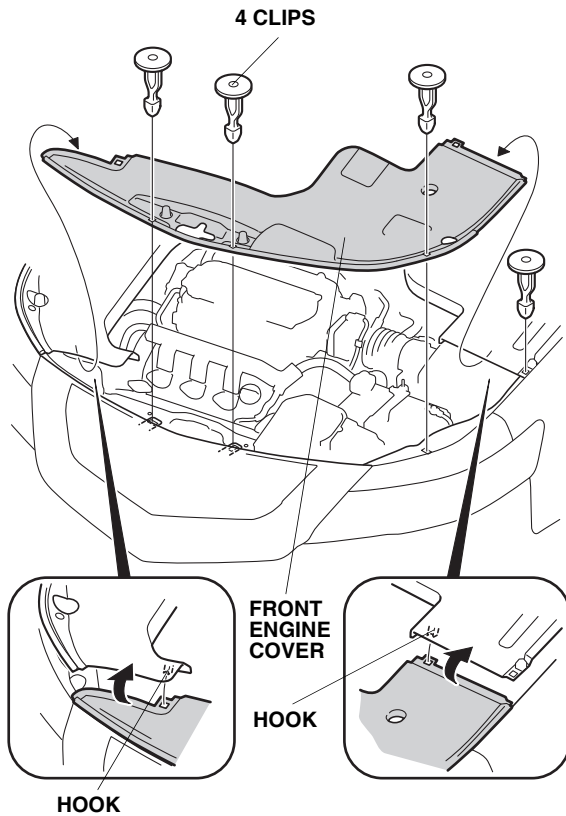

3. Disconnect the negative cable from the battery.

4. Open the trunk lid, and remove the trunk floor and the tool box spacer.

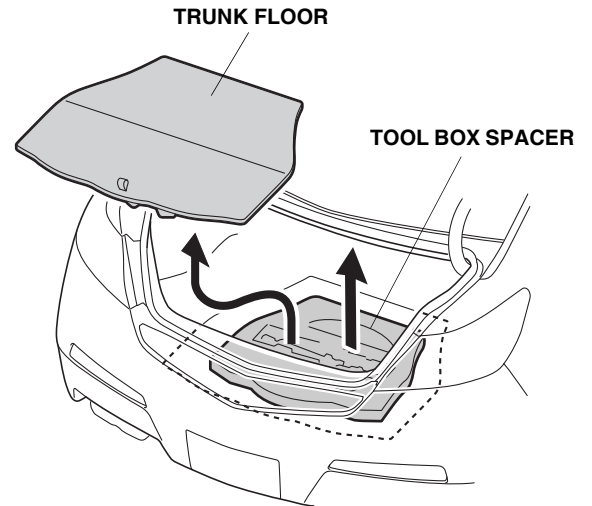

5. Pull away the weatherstrip, and remove the trunk rear trim panel (four clips, two tabs, and two hooks).

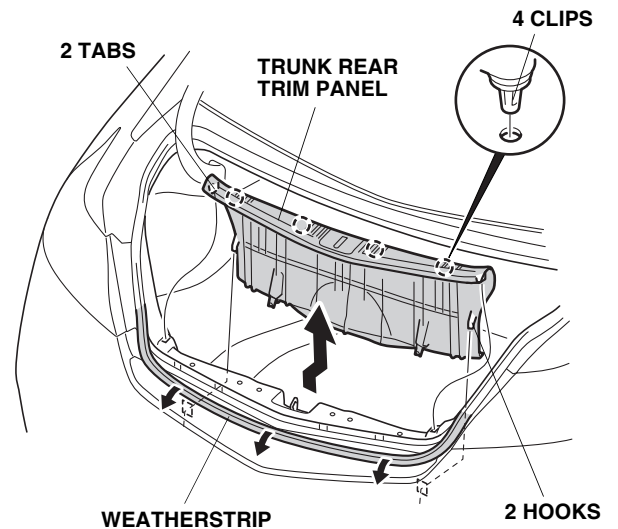

- Remove the trunk front trim panel (two clips and four fasteners).

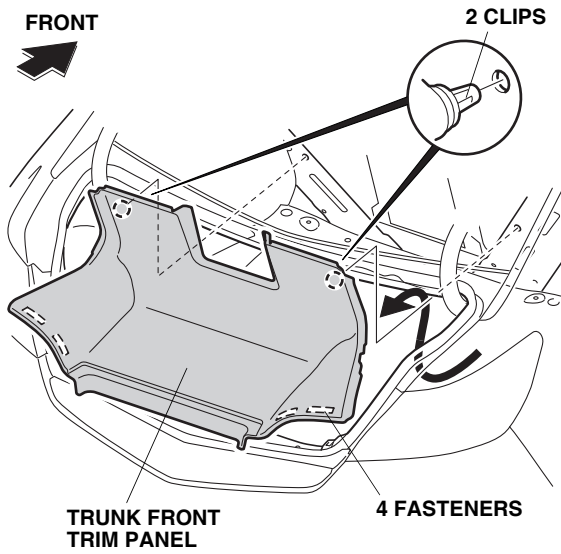

- Pull away the weatherstrip, and remove the left trunk side trim panel (two clips and four cargo hook buttons).

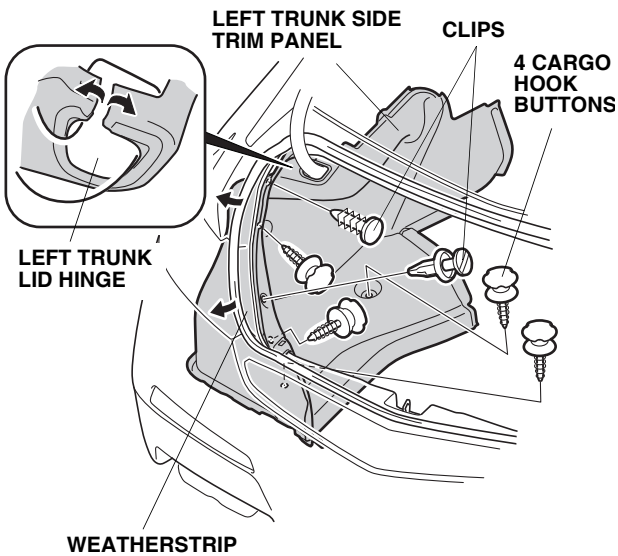

- Pull down the trunk upper trim panel (four clips).

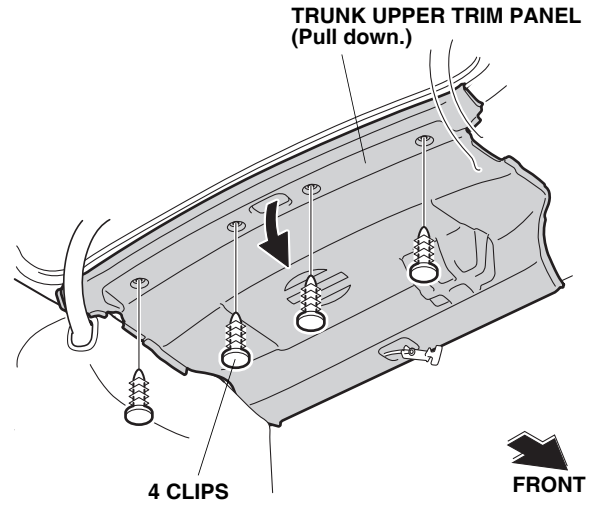

- Remove the eight self-tapping screws and two clips from the rear bumper.
NOTE: If equipped, remove the rear splash guards.

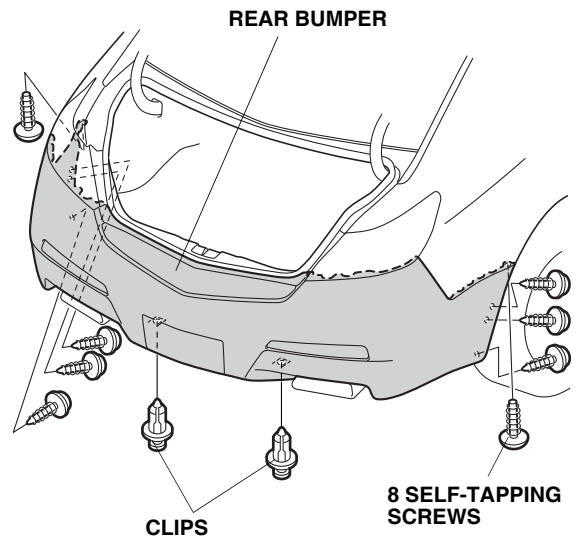

10. On each side, release the twelve hooks, and pull the rear bumper out from the body.

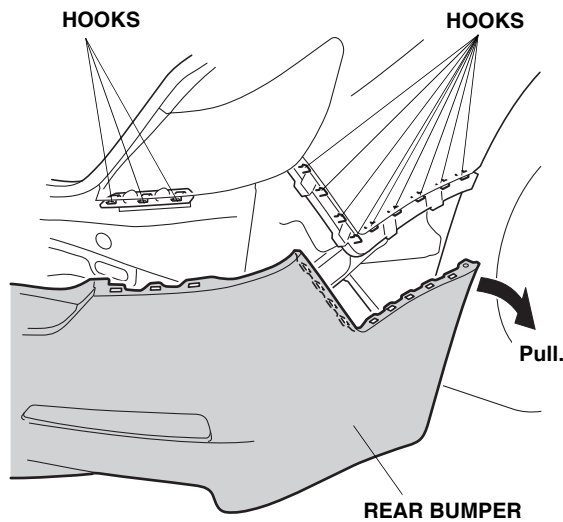

11. With the help from an assistant, remove the rear bumper (four hooks, and unplug the two vehicle connectors). Place the rear bumper on the blanket to prevent damage.

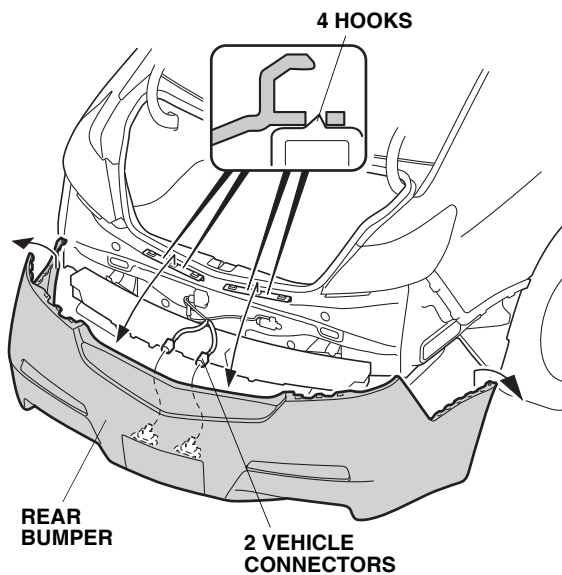

Installing the Control Unit

12. Attach the control unit bracket to the control unit. Pay attention to the direction of control unit and control unit bracket.

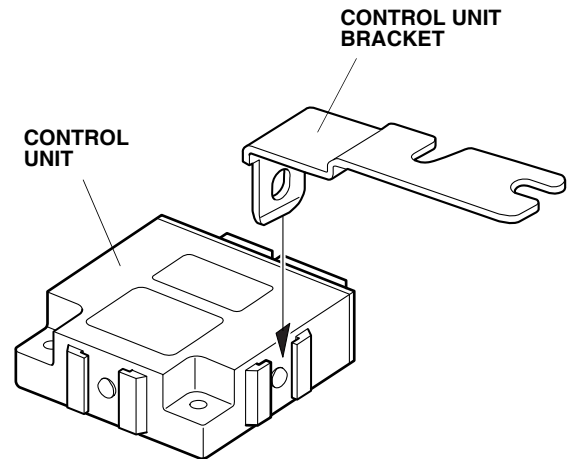

13. Inside the left trunk area, loosen the two vehicle bolts.

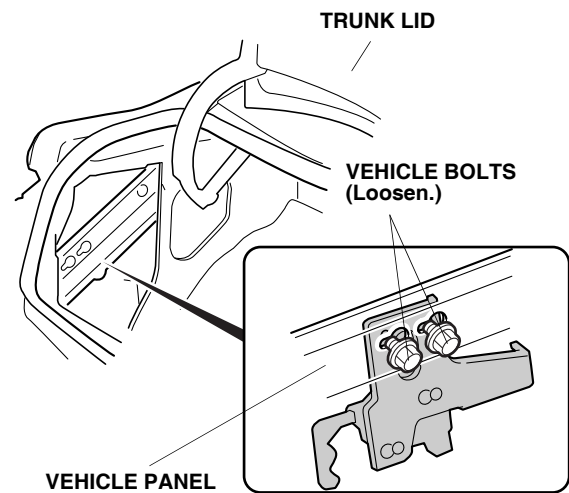

- Slide the control unit bracket under the two vehicle bolts, and tighten the bolts to secure the control unit bracket.

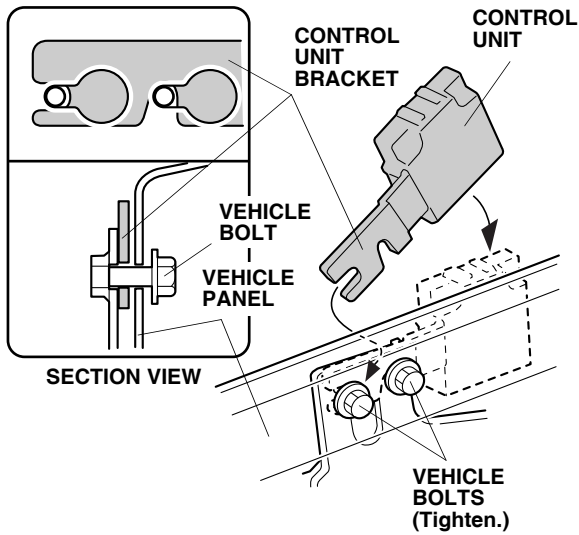

Installing the Buzzer

- Using isopropyl alcohol on a shop towel, clean the area where the urethane tape will attach.

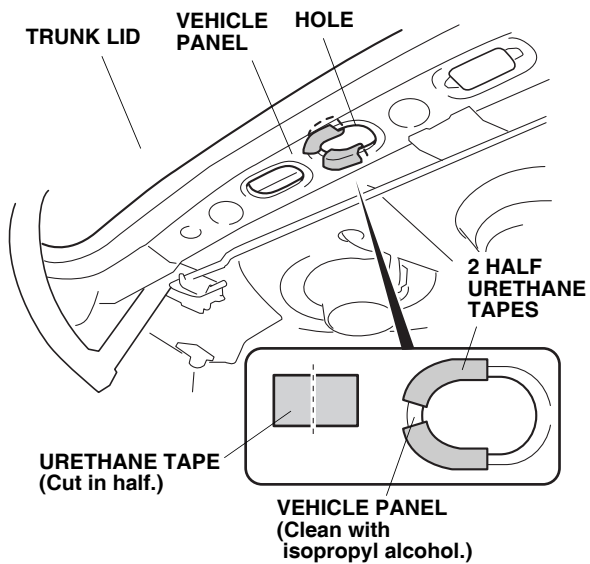

- Cut one urethane tape in half. Attach the two cut pieces of urethane tape around the vehicle panel hole as shown.

- Using isopropyl alcohol on a shop towel, clean the area where the buzzer will attach.

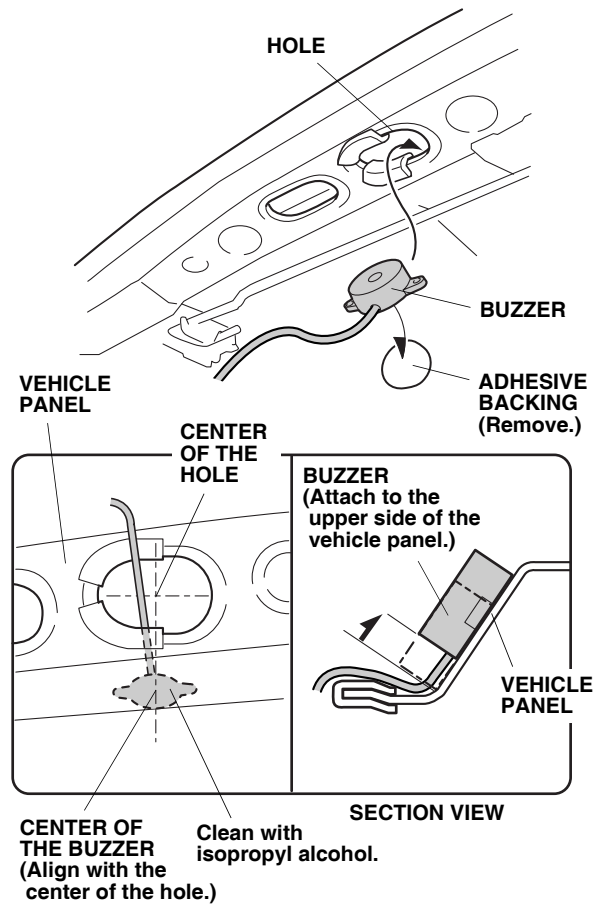

- Remove the adhesive backing from the buzzer.
- Align the center of the buzzer with the center of the vehicle panel hole, and attach the buzzer to the upper side of the vehicle panel.

- Route the buzzer harness along the rear shelf and above the left trunk lid hinge arm.

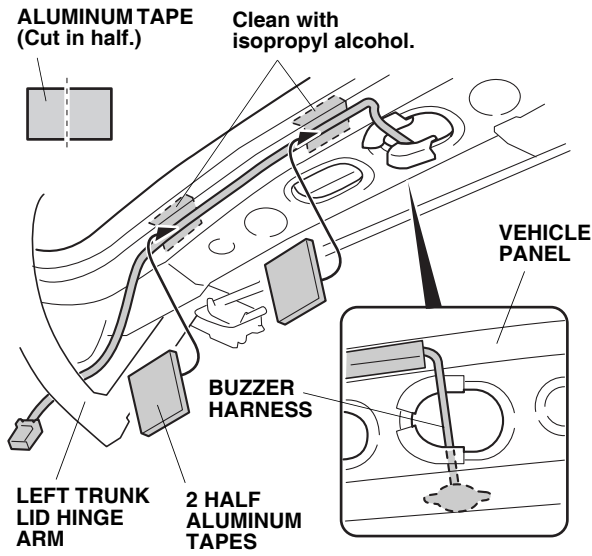

- Using isopropyl alcohol on a shop towel, clean the areas where the aluminum tape will attach.
- Using scissors, cut one aluminum tape in half. Secure the buzzer harness to the rear shelf using the two pieces of aluminum tape.
- Route the buzzer harness through the hole in the vehicle panel.

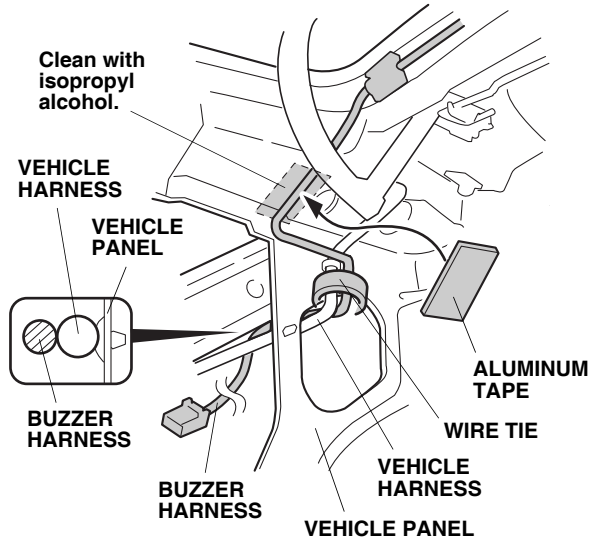

- Using isopropyl alcohol on a shop towel, clean the area where the aluminum tape will attach.
- Secure the buzzer harness to the vehicle panel using one aluminum tape. Secure the buzzer harness to the vehicle harness with one wire tie.

Routing the Sensor Harness

- Using isopropyl alcohol on a shop towel, clean the fuse case where the 2 A rear sensor fuse seal will attach.

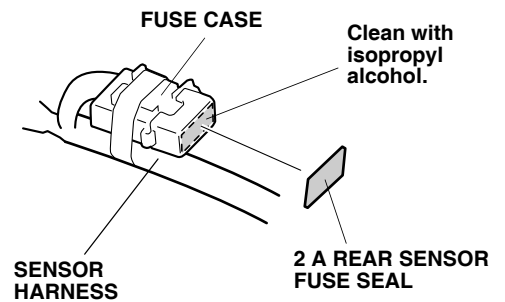

- Attach the 2 A rear sensor fuse seal to the sensor harness fuse case.
- Plug the buzzer harness 5-pin connector into the control unit.

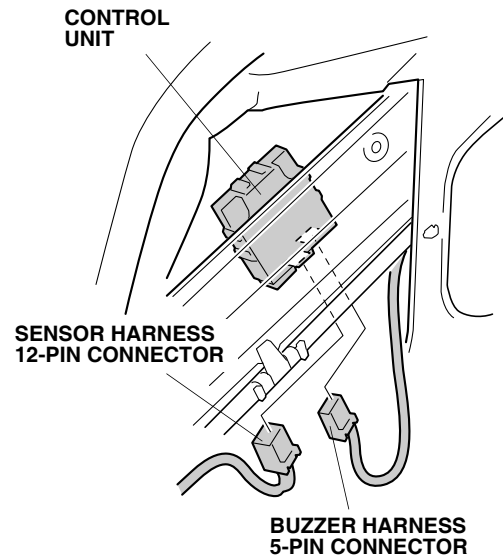

- Plug the sensor harness 12-pin connector into the control unit.

30. Bundle up the excess buzzer harness and secure it to the vehicle harness with one wire tie.

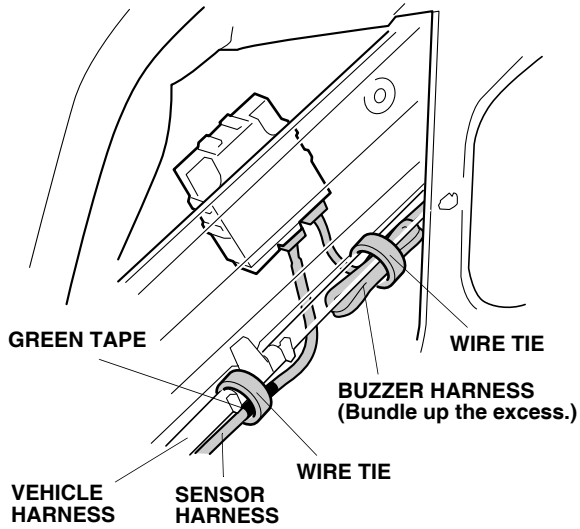

31. Secure the sensor harness to the vehicle harness using one wire tie at the green tape position.
 32. Remove the grommet from the rear panel.

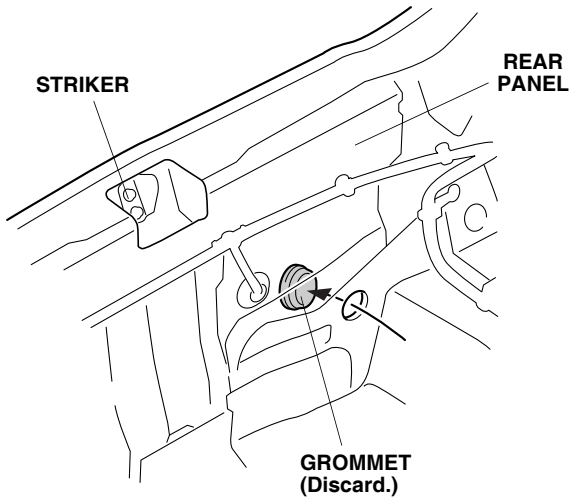

33. Route the sensor harness along the vehicle harness.

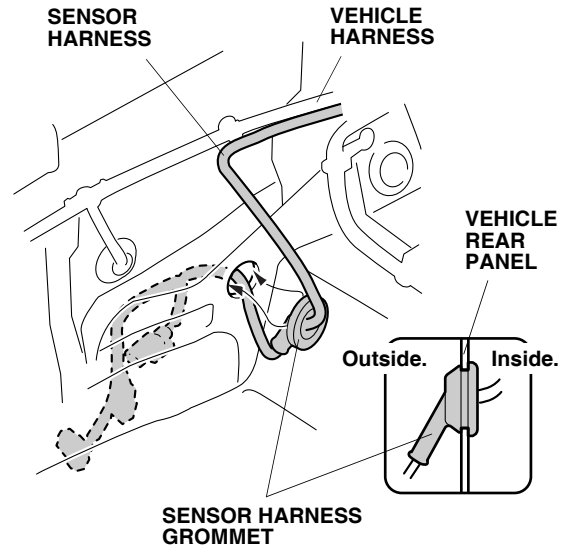

34. Route the sensor harness through the vehicle grommet hole, and seat the sensor harness grommet onto the rear panel as shown.
 35. Secure the sensor harness to the vehicle harness using five wire ties.

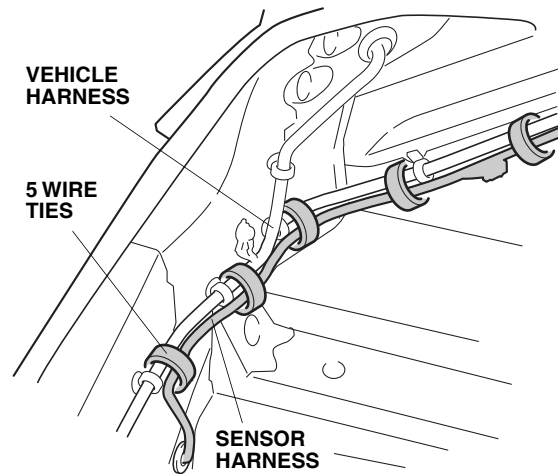

36. Install the holder to the sensor harness 6-pin connector.

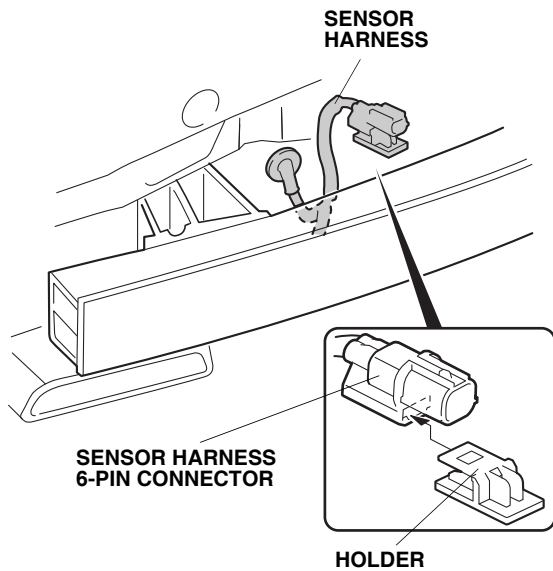

37. Using isopropyl alcohol on a shop towel, clean the area where the holder will attach.

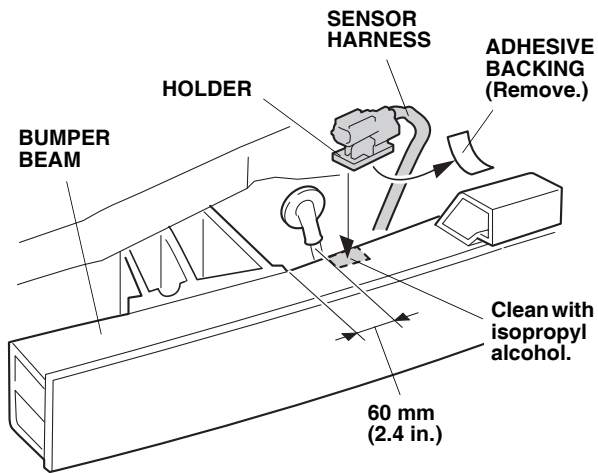

38. Remove the adhesive backing from the holder, and attach the holder at the position shown.

39. Remove the three cap nuts from the left taillight.

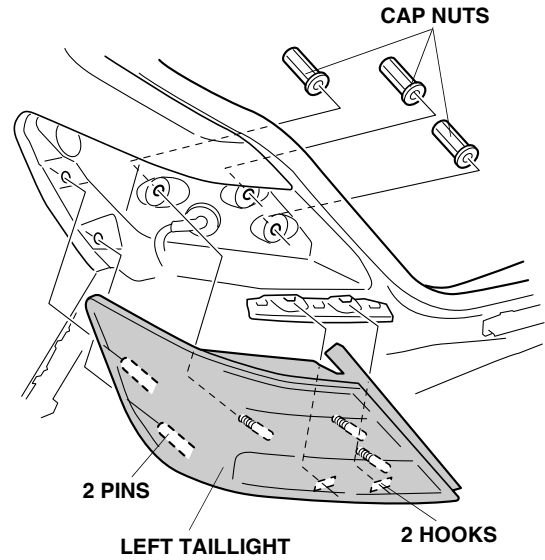

40. Release the two hooks and two pins, and pull the left taillight out toward you.
41. Unplug the vehicle harness 2-pin connector from the left taillight 2-pin connector.

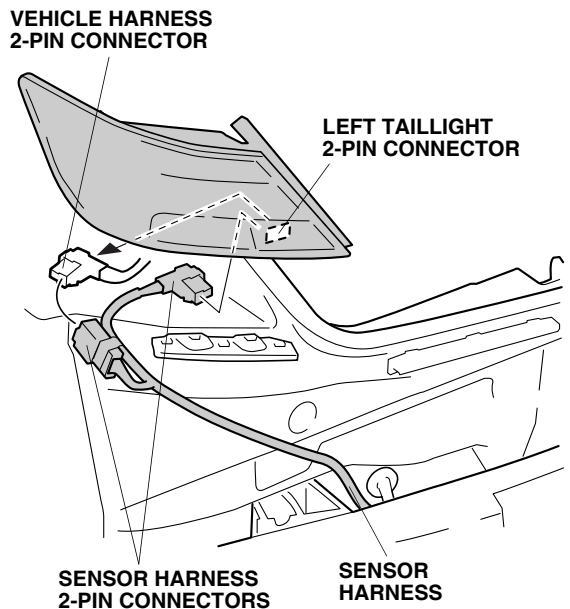

42. Plug the sensor harness 2-pin connector into the left taillight 2-pin connector, and plug the vehicle harness 2-pin connector into the sensor harness 2-pin connector.

43. Secure the sensor harness to the vehicle harness using one wire tie, and reinstall the left taillight.

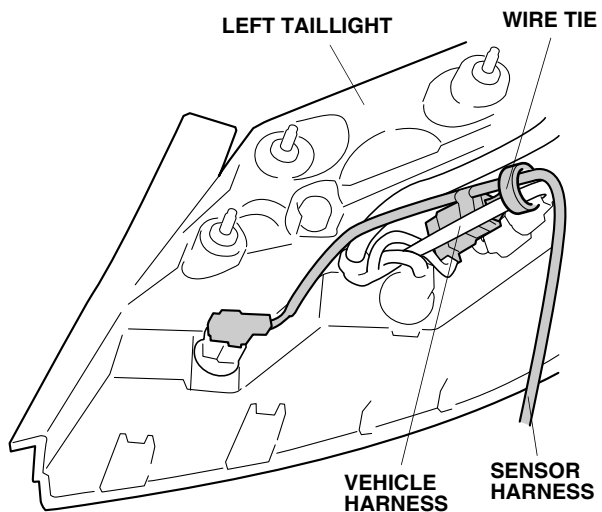

44. Using isopropyl alcohol on a shop towel, clean the areas where the aluminum tape will attach.

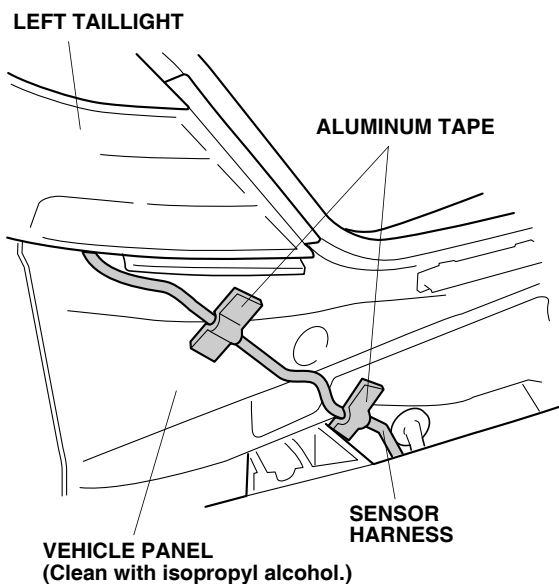

45. Secure the sensor harness to the vehicle panel using two aluminum tapes.

Installing the Sensors

46. On the inside of the rear bumper, locate the four preset marks. Using a pushpin, pierce the bumper at the four center and the four top scribe marks.

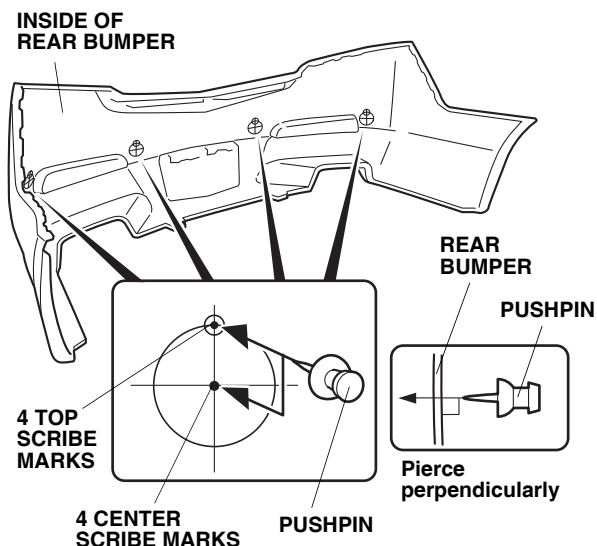

47. While wearing eye protection, drill all eight pierced points using a 3 mm drill bit from the outside of the rear bumper.

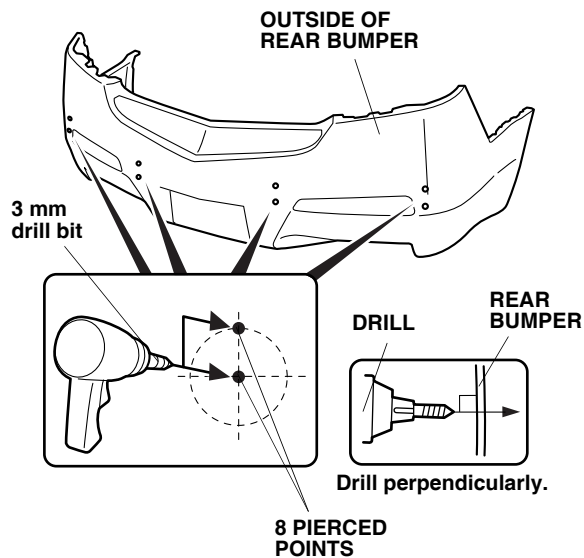

48. While wearing eye protection, drill the two outboard lower holes to 24 mm using a 24 mm hole saw. Drill the outside of the rear bumper.

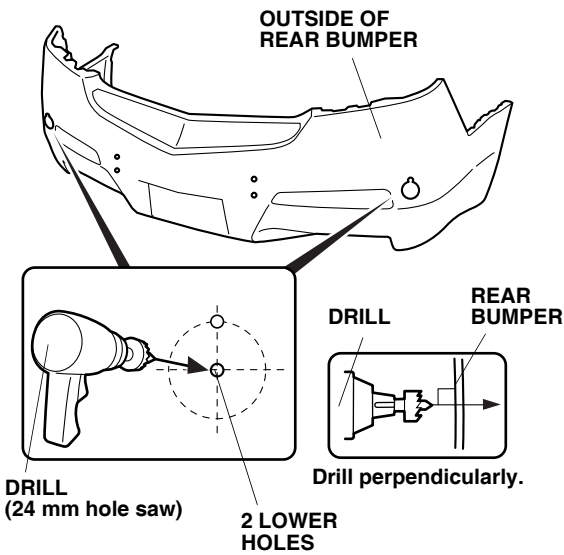

49. While wearing eye protection, drill the two inboard lower holes to 26 mm using a 26 mm hole saw. Drill from the outside of the rear bumper.

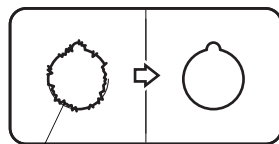
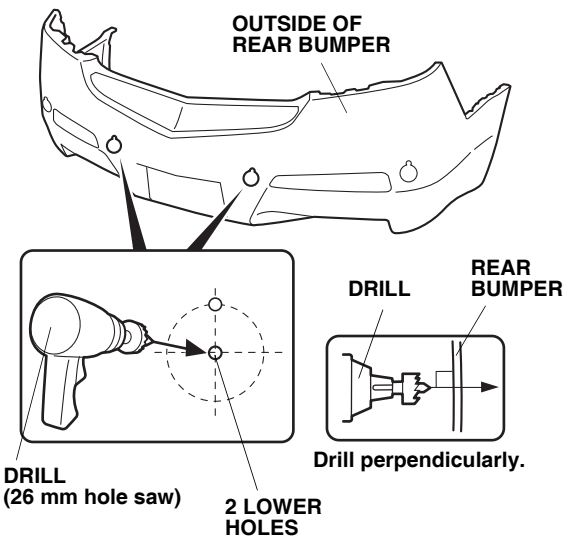

Remove burrs.

50. Remove any burrs from all of the drilled holes.
NOTE: The sensors will not seat properly unless the burrs are removed.

51. Align the stopper of each center sensor (BLUE) with the groove in the hole, and install two center sensors (BLUE) into the inboard 26 mm holes in the rear bumper.

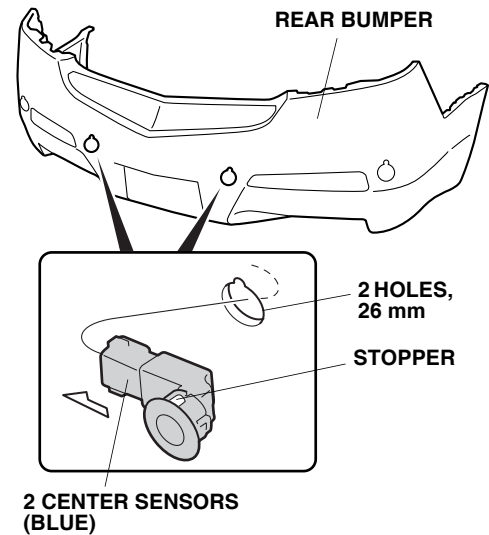

52. Install one sensor clip to each center sensor (BLUE).

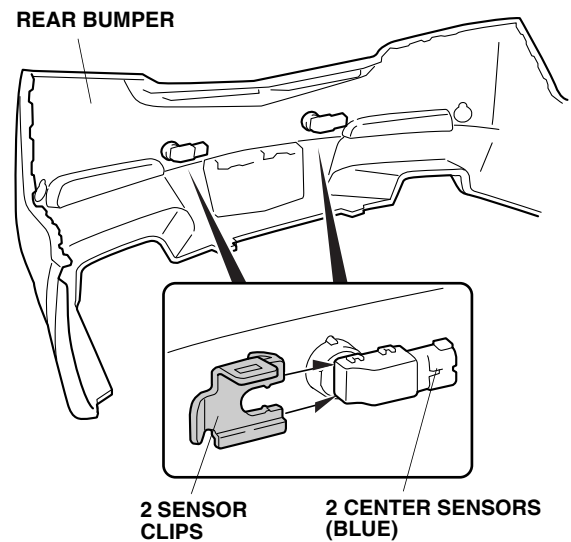

53. Align the stopper of each corner sensor (WHITE) with the groove in the hole, and install two corner sensors (WHITE) into the outboard 24 mm holes in the rear bumper.

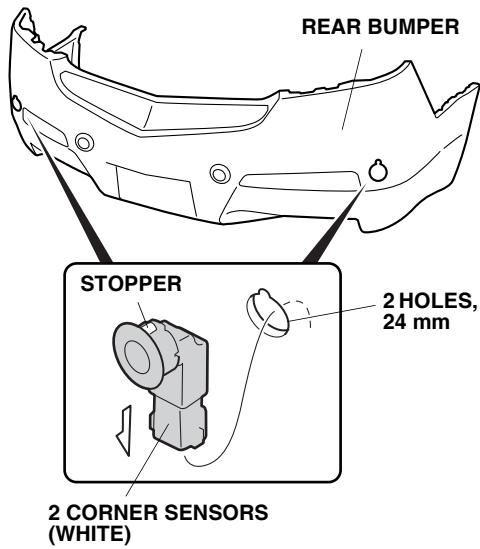

54. Install one sensor clip to each corner sensor (WHITE).

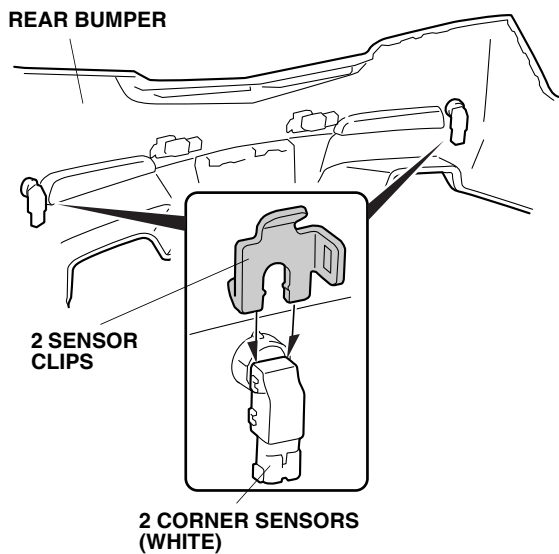

Routing the Sub Harness

55. Plug in the four sub harness 2-pin connectors to the two center sensors, and the two corner sensors.

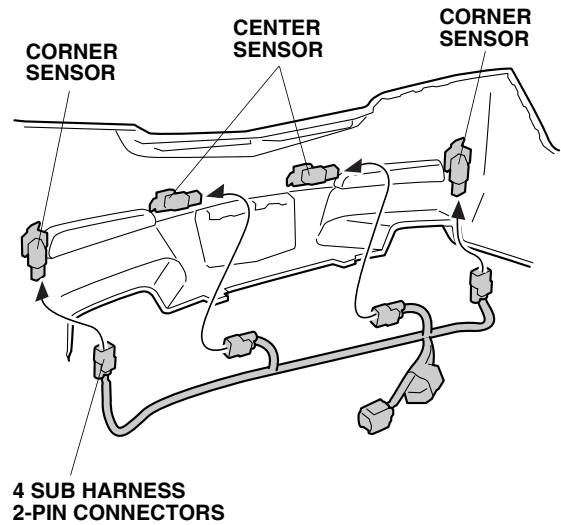

56. Attach one wire tie with clip A to the sub harness at the green tape, and secure the sub harness to the ribs on the rear bumper using two wire ties with clip A.
- NOTE: Pay attention to the direction of the wire ties with clip A.

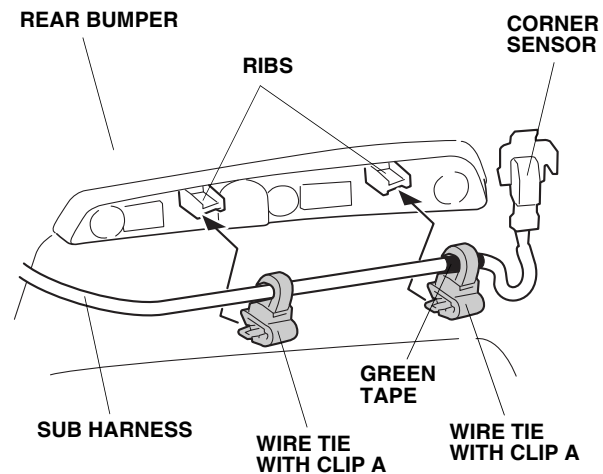

- On the other side of the bumper, attach the wire tie with clip A to the sub harness at the green tape, and secure the sub harness to the ribs of the rear bumper using two wire ties with clip A.

NOTE: Pay attention to the direction of the wire ties with clip A.

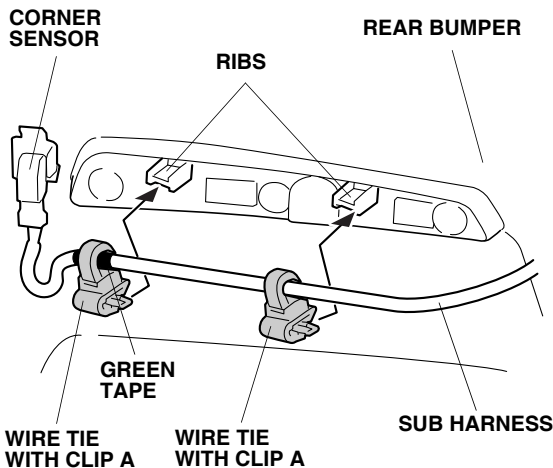

- Attach the wire tie with clip B to the sub harness at the green tape, and secure the sub harness to sensor clips using two wire ties with clip B.

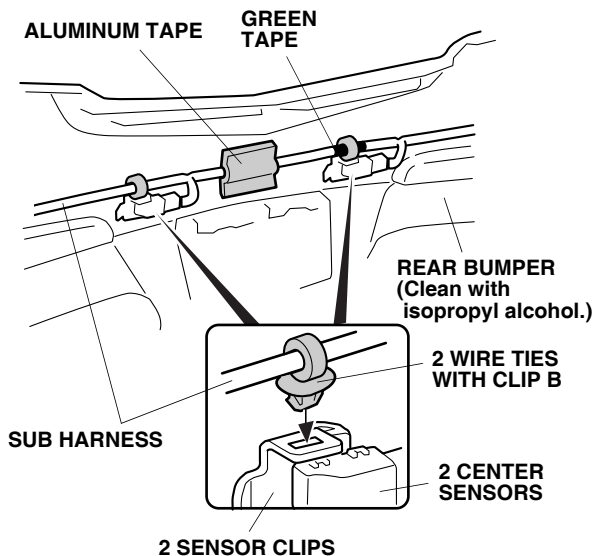

- Using isopropyl alcohol on a shop towel, clean the area where the aluminum tape will attach.
- Secure the sub harness to the rear bumper using one aluminum tape.

- With the help from an assistant, move the rear bumper close to the vehicle. Plug the sub harness 6-pin connector into the sensor harness 6-pin connector, and reinstall the rear bumper.

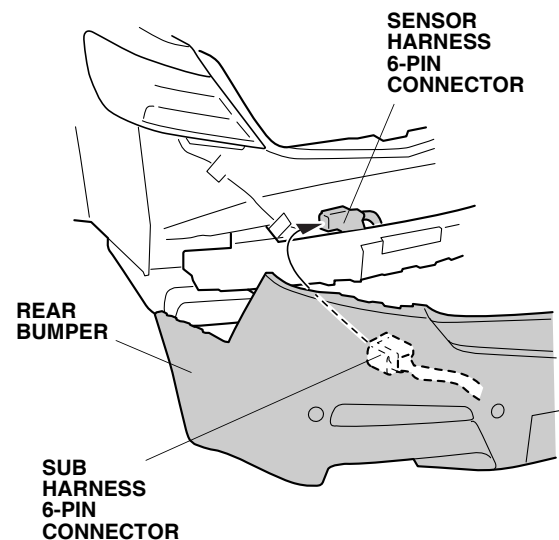

- Check that all wire harnesses are routed properly and all connectors are plugged in.
- Reinstall all removed parts except for the front engine cover.
- Connect the negative cable to the battery and check operation of all of the lights.
- Reinstall the front engine cover.
- Enter the anti-theft codes for the audio system and the navigation system (if equipped).
- Reset the clock on vehicles without navigation.
- Check that the back-up sensors work properly as described in the Accessory User's Information Manual supplied with the back-up sensors attachment kit.

Buzzer Volume Control

The original volume setting is turned to maximum volume. The volume level can be adjusted by turning the volume control knob on the control unit using a small flat-tip screwdriver.

